



A

2022.4.28

ALL

/ Descriptions

650V

/ Features

/ Applications

/ Equivalent Circuit

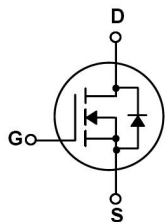

/ Pinning



/ Marking

--	--	--	--	--	--	--	--



/ Electrical Characteristic Curve

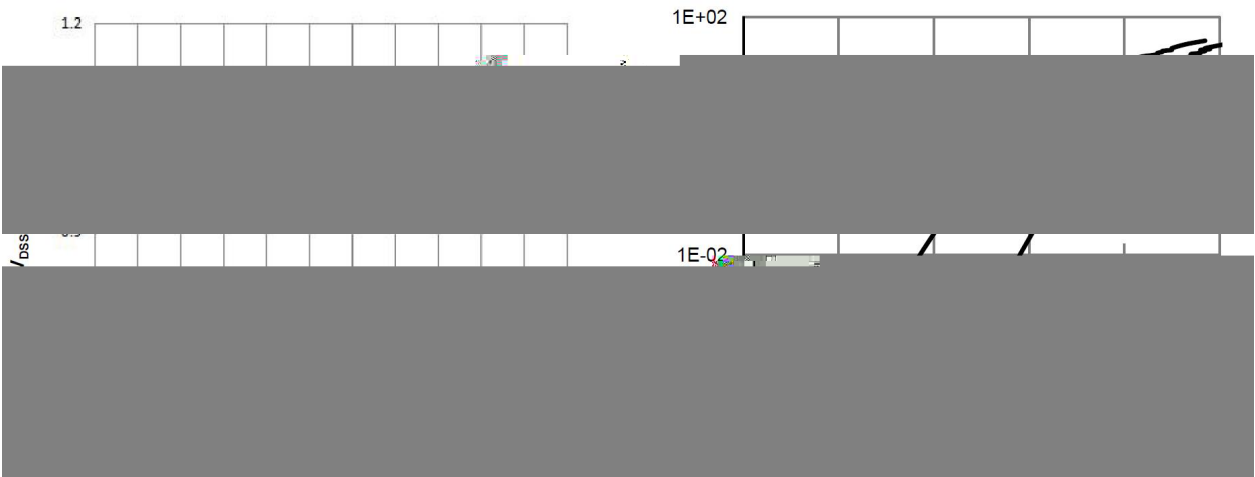
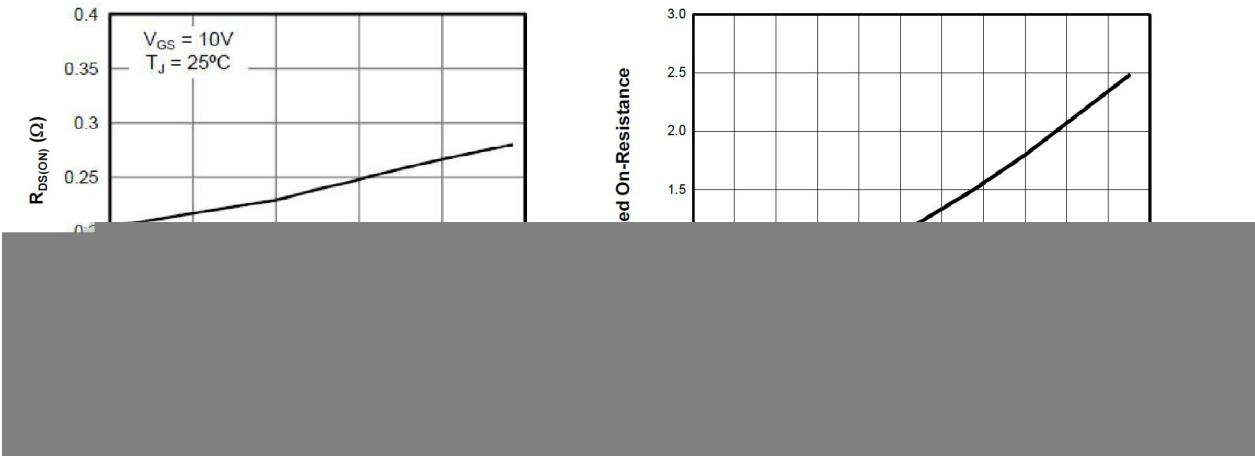
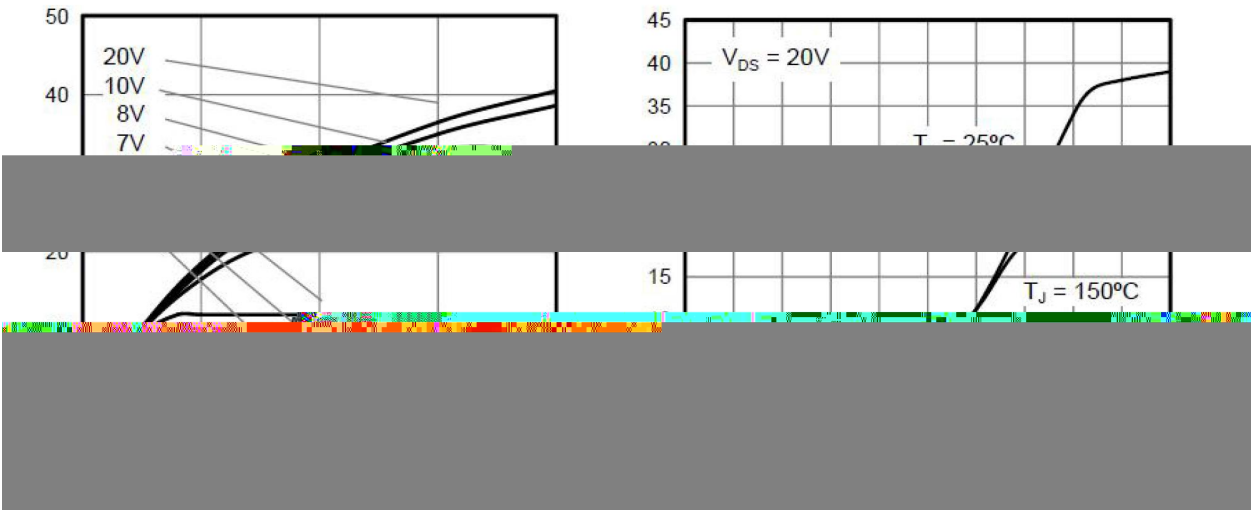



/ Electrical Characteristic Curve

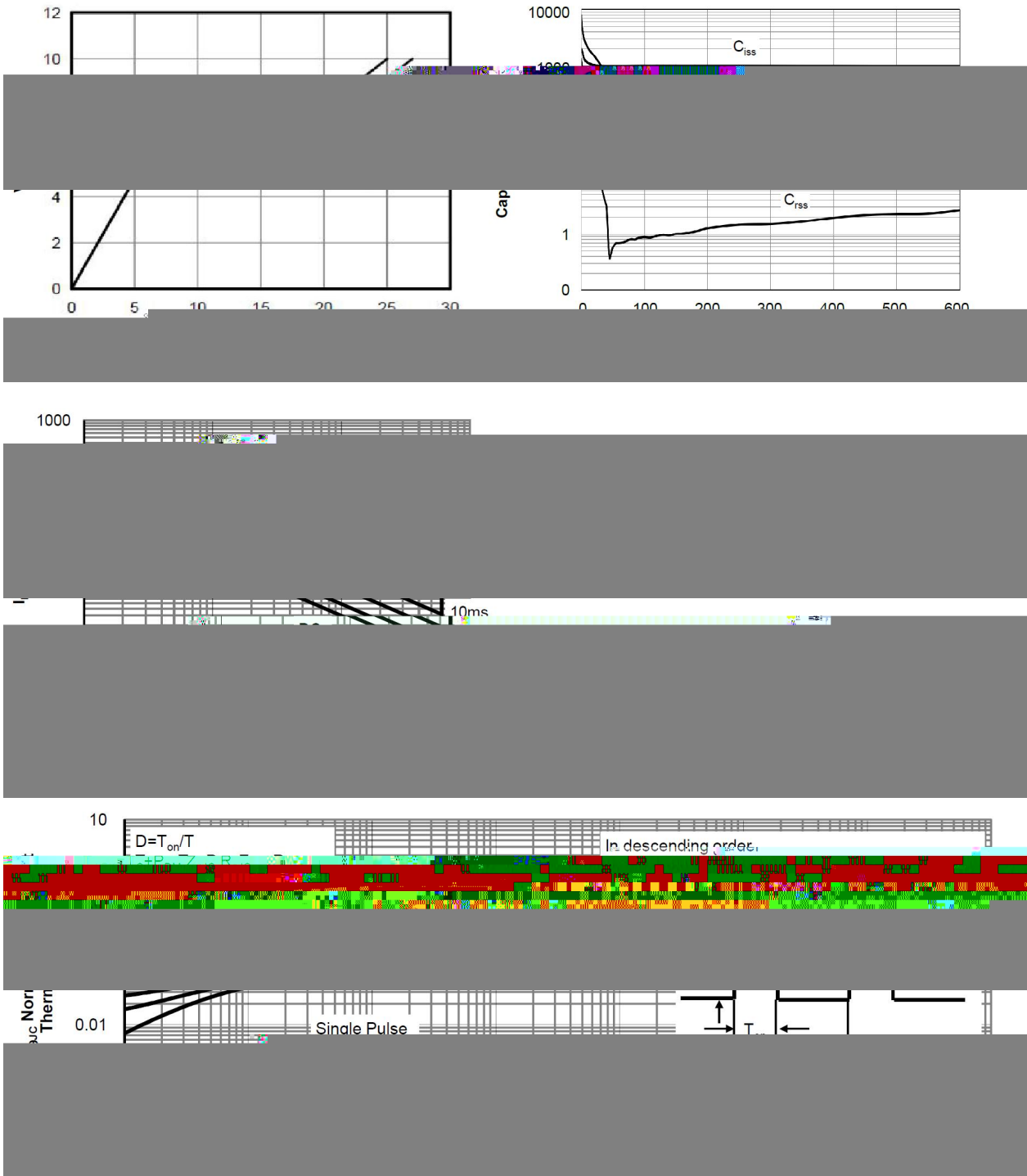

/ Package Dimensions

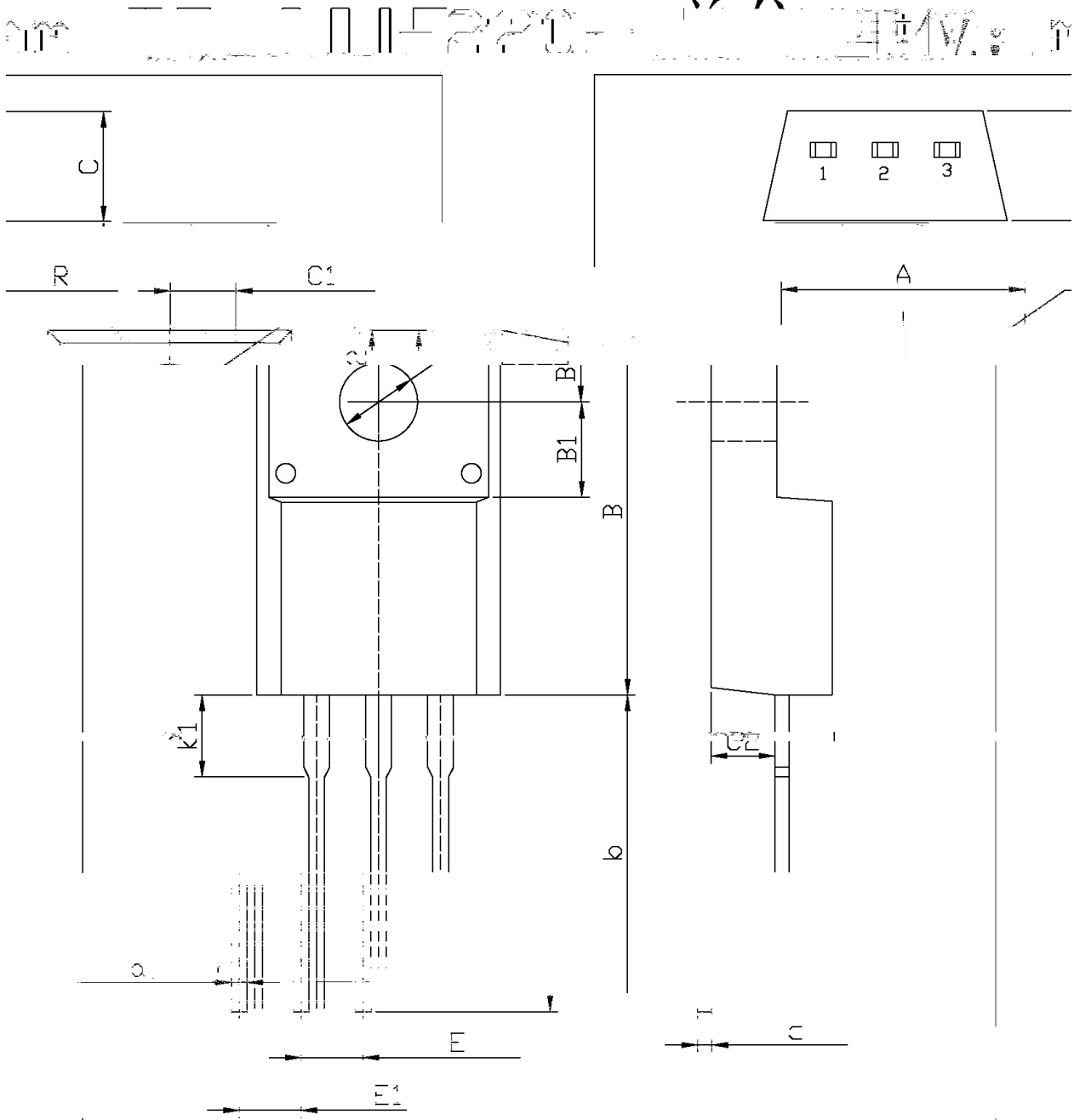

Symbol	Dimensions In Millimeters		Symbol	Dimensions In Millimeters	
	Min	Max		Min	Max
B1	0.8	4.0	E1	2.89	2.75
B2	2.9	3.1	C1	2.5	2.9
R	3.0	3.4	C2	2.5	2.7
b	12.5	13.5	c	0.5	0.7

/ Marking Instructions

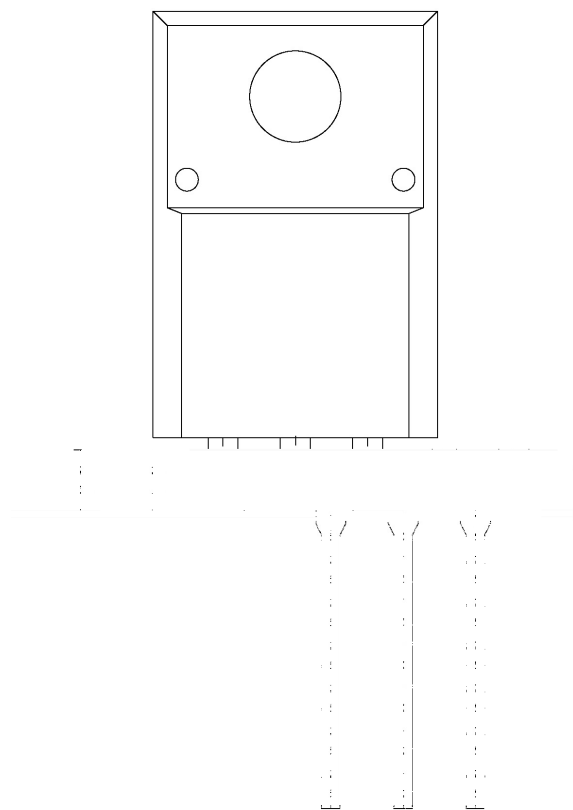

说明：
： 为公司代码
65R280C： 为型号代码
****： 为生产批号代码，随生产批号变化

() / Temperature Profile for Dip Soldering(Pb-Free)

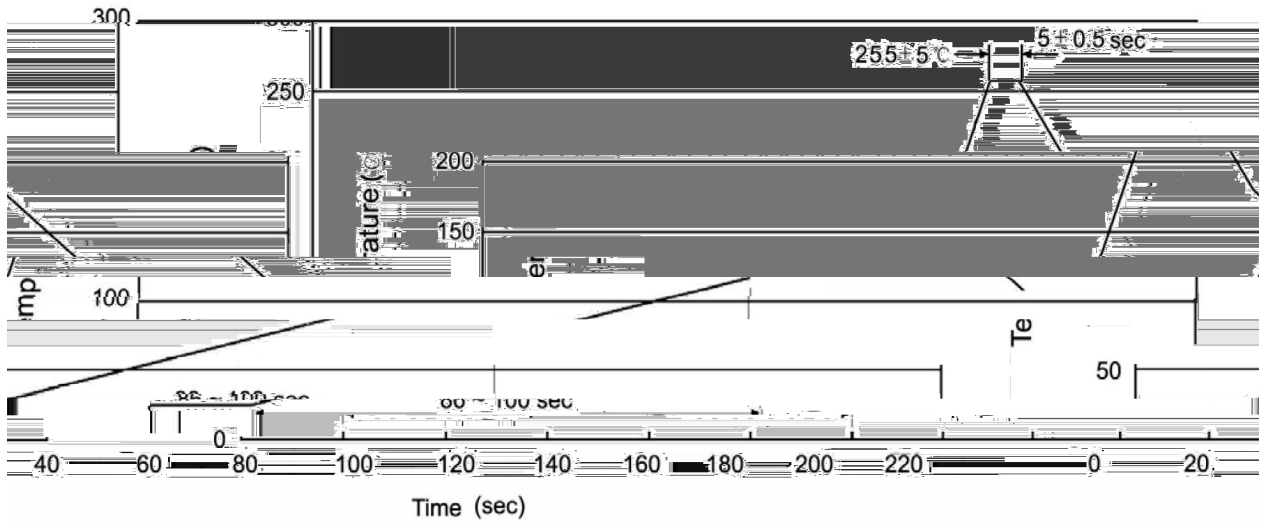

说明：

- 、预热温度 ~ °C，时间 ~ °C
- 、峰值温度 ± °C，时间持续为 ± °C ±
- 、焊接制程冷却速度为 ~ °C °C

/ Resistance to Soldering Heat Test Conditions

温度： ± °C 时间： ± °C

/ Packaging SPEC.

散件包装

封装形式	包装数量	包装尺寸	：	袋	盒	箱
------	------	------	---	---	---	---