

/ Descriptions

/ Features

/ Applications

DC-DC

/ Equivalent Circuit

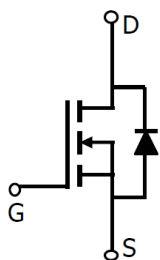

/ Pinning

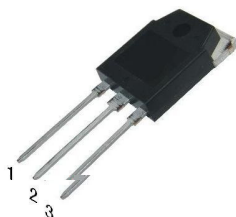

/ h_{FE} Classifications & Marking

/ Absolute Maximum Ratings(Ta=25)

			°C

- 1.
- 2.

/ Thermal Data

/ Electrical Characteristic Curve

On-Region Characteristics

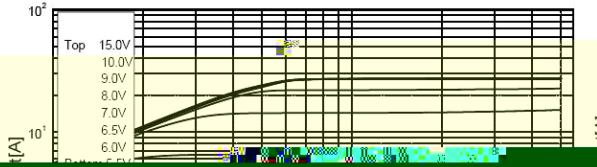

Transfer Characteristics

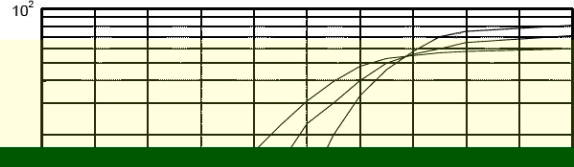

On-Resistance Variation vs. Drain Current and Gate Voltage



Body Diode Forward Voltage Variation vs. Source Current and Temperature

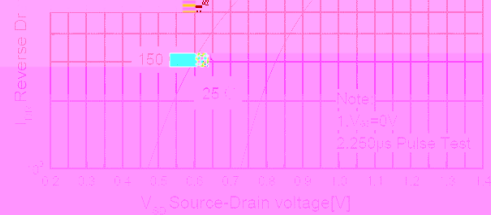
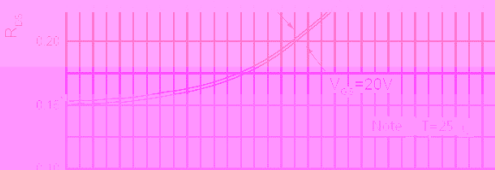
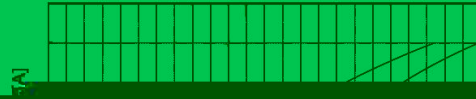

Capacitance Characteristics

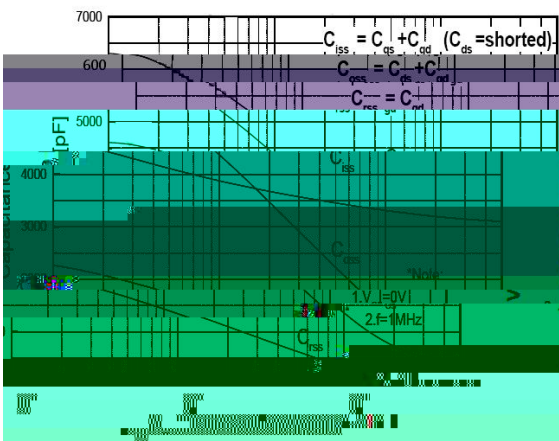

Capacitance Characteristics

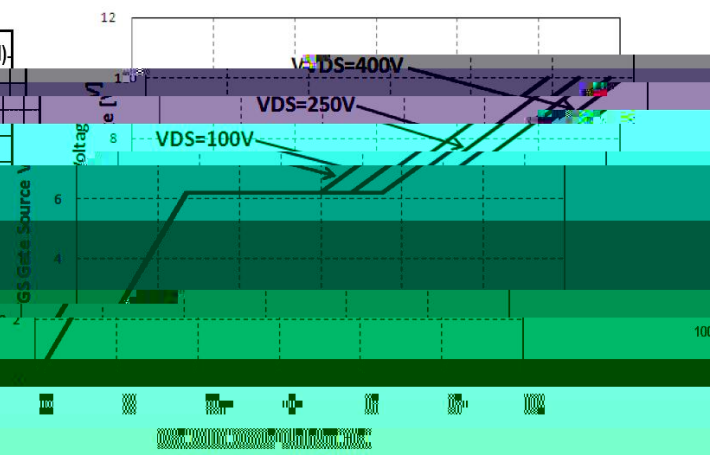

/ Electrical Characteristics(Ta=25)

Breakdown Voltage Variation vs. Temperature

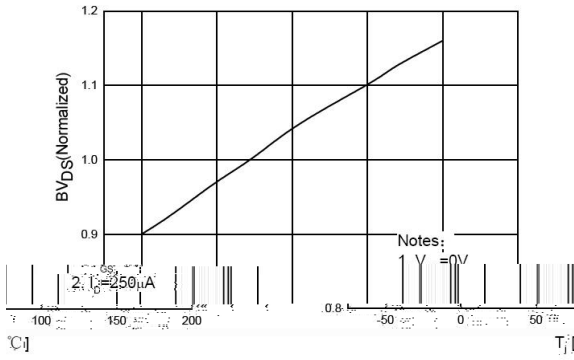

On-Resistance Variation vs. Temperature

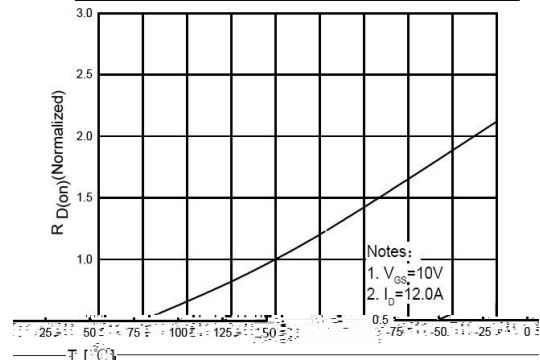

Maximum Safe Operating Area

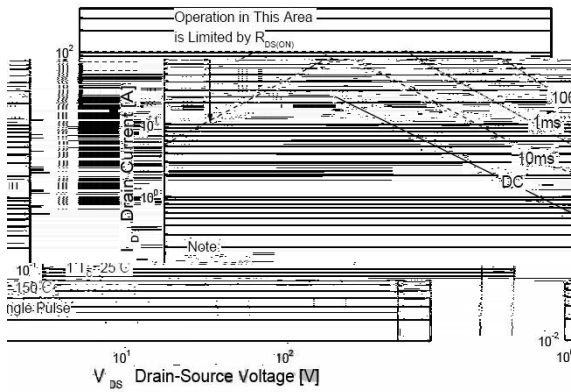

Transient Thermal Response Curve

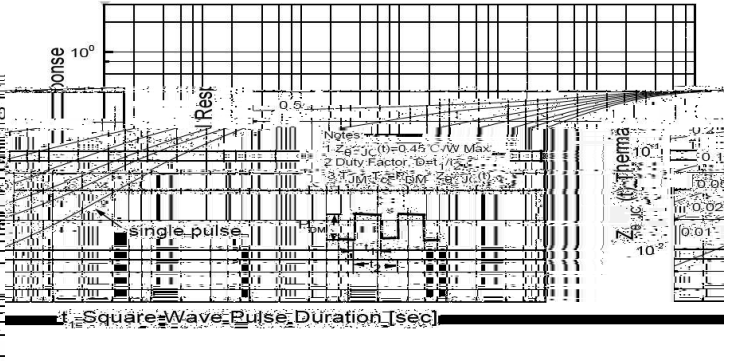

/ Package Dimensions

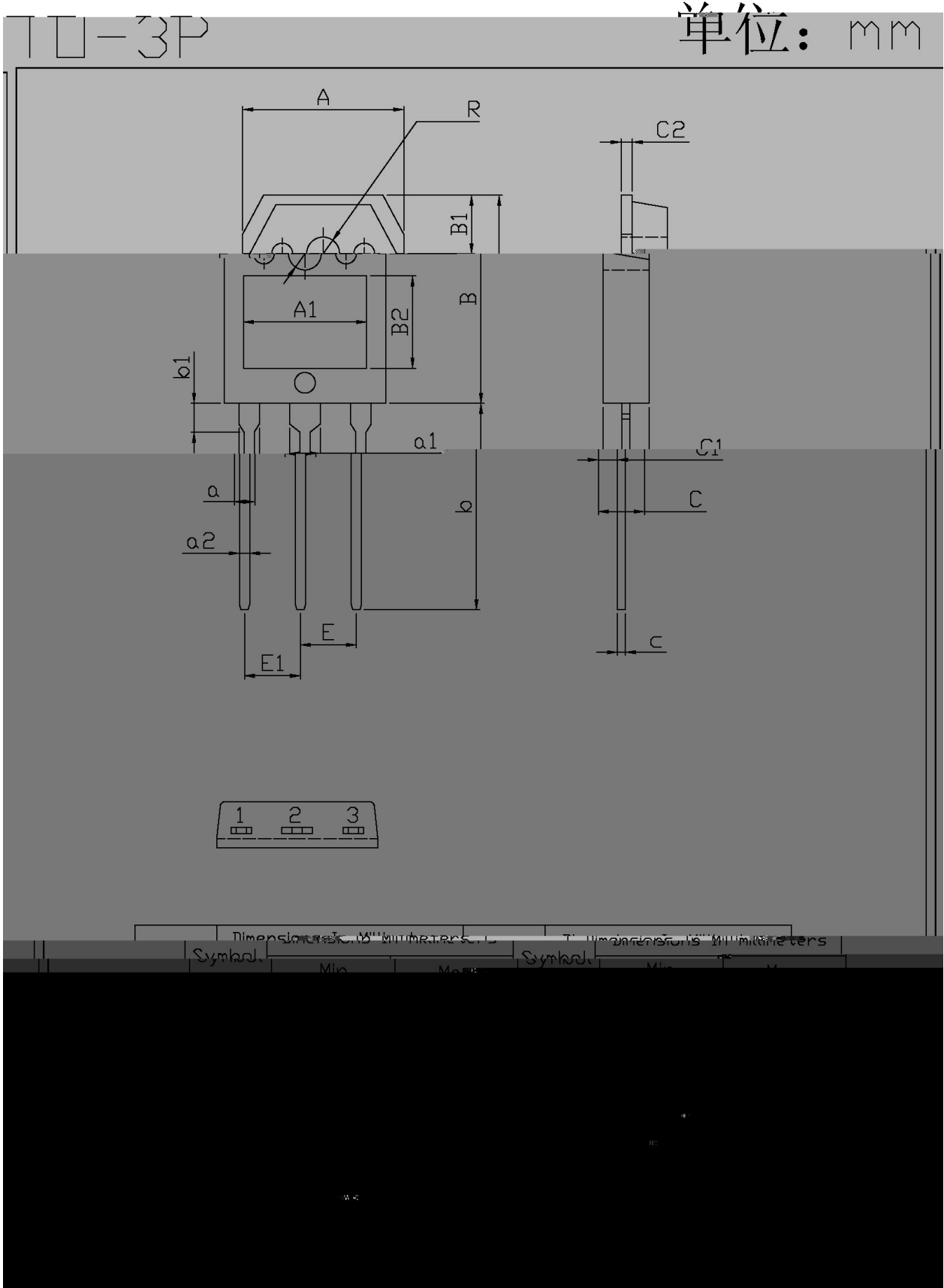

/ Marking Instructions

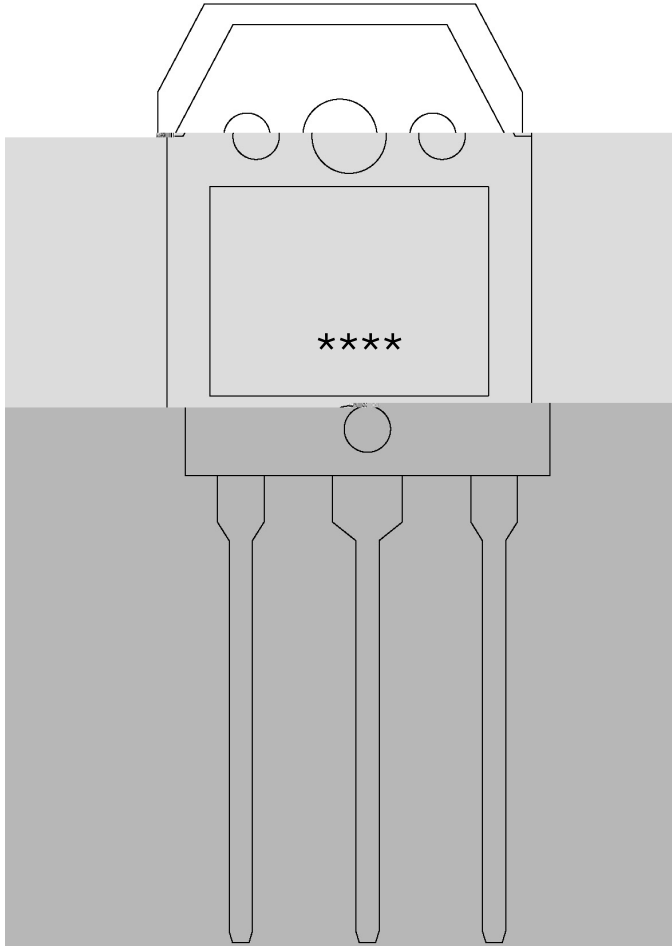

:

() / Temperature Profile for Dip Soldering(Pb-Free)

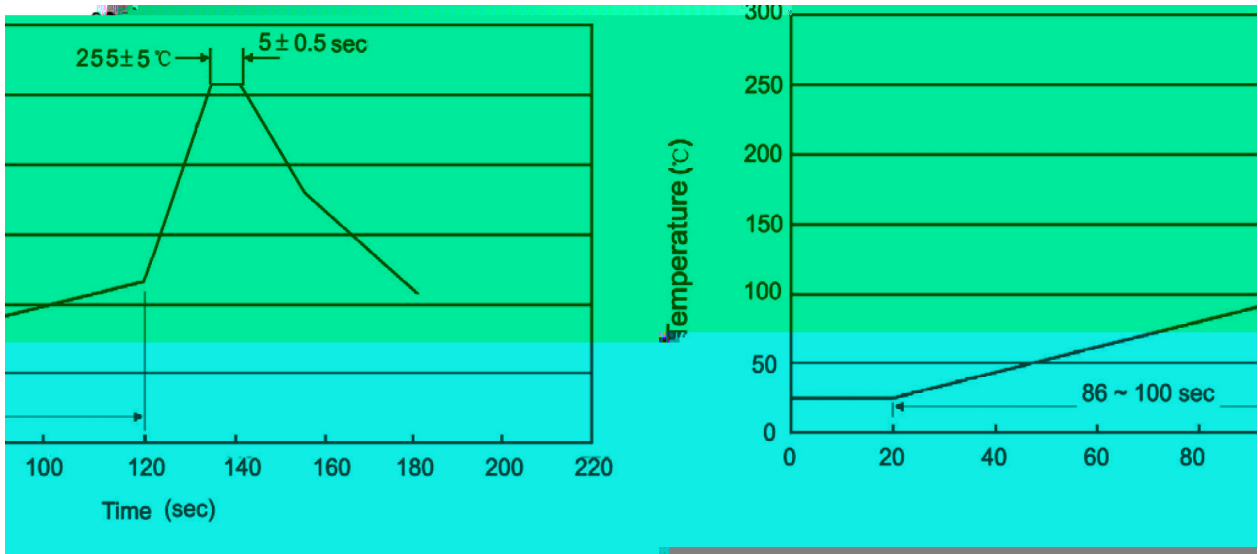

± ± ± ±

/ Resistance to Soldering Heat Test Conditions

± ±

/ Packaging SPEC.

封装形式	包装数量					包装尺寸 :		
	Units/Tube 只/套管	Tubes/Inner Box 套管/盒	Units/Inner Box 只/盒	Inner Boxes/Outer Box 盒/箱	Units/Outer Box 只/箱	Tube 套管	Inner Box 盒	Outer Box 箱
TO-3P	30	15	450	5	2250	497.5×46×8	555×164×50	575×290×180

/ Notices