

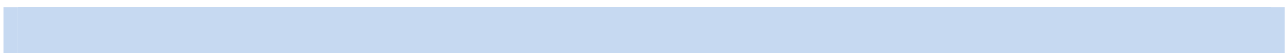

P

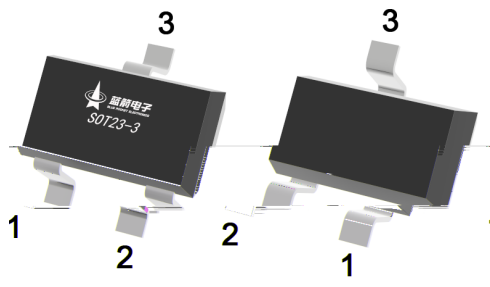

Ω  
Ω  
Ω

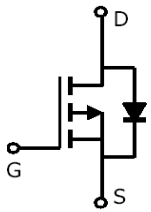
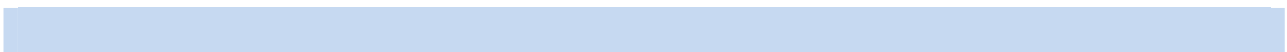
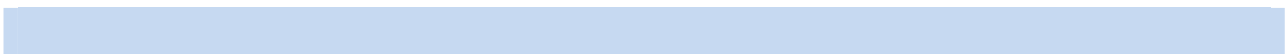

--	--





		Ω				

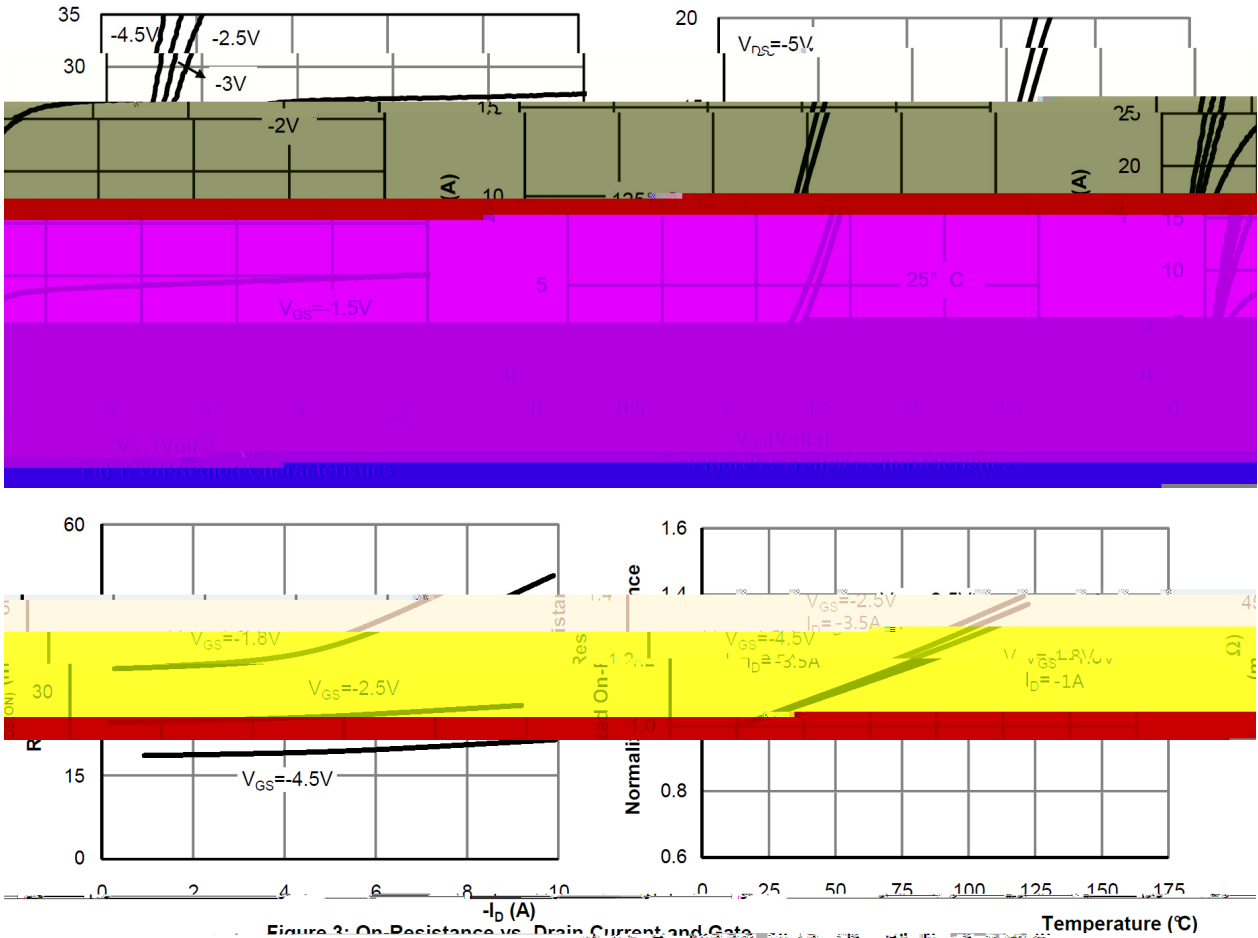

Figure 3: On-Resistance vs. Drain Current and Gate Voltage

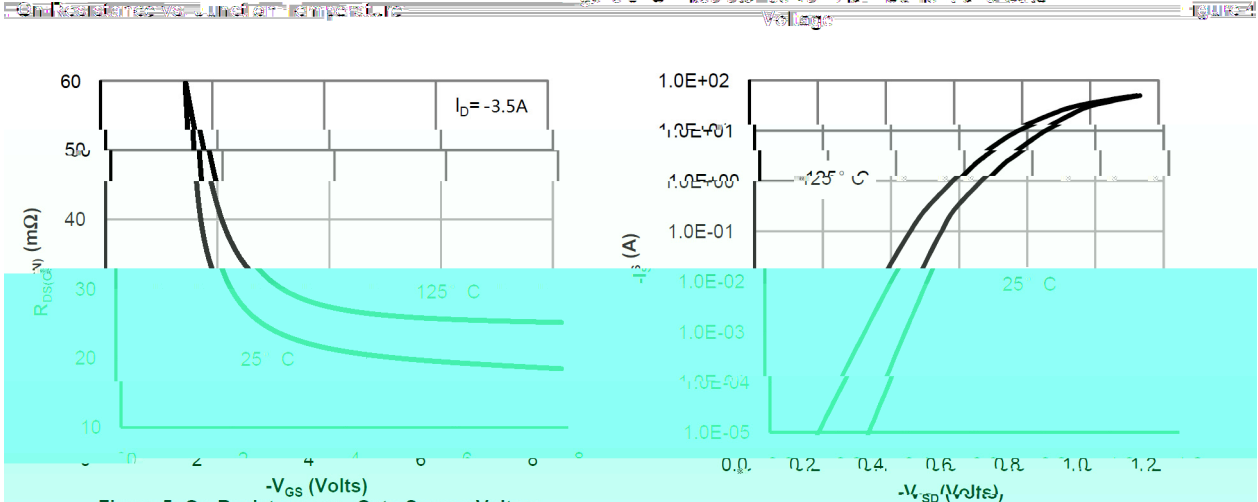

Figure 5: On-Resistance vs. Gate-Source Voltage

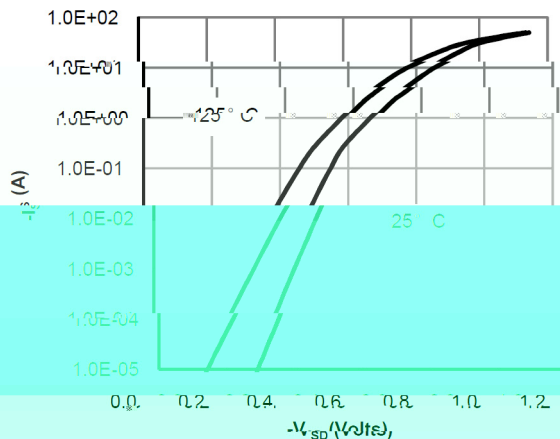
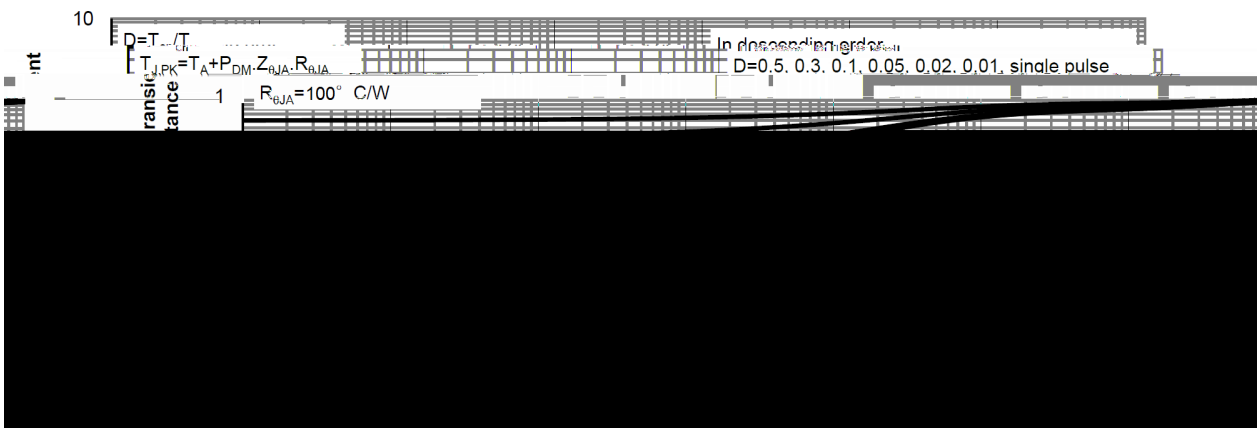
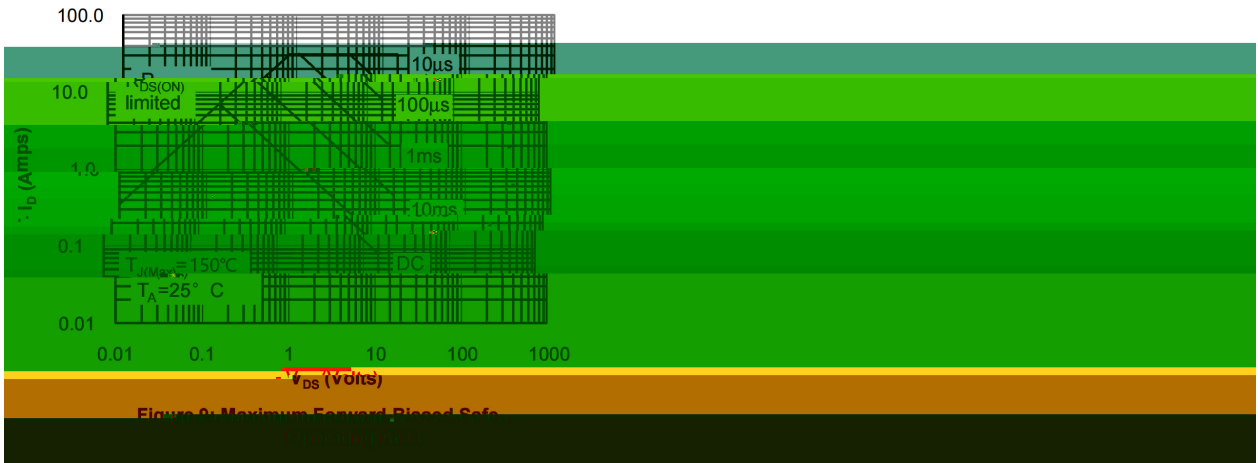
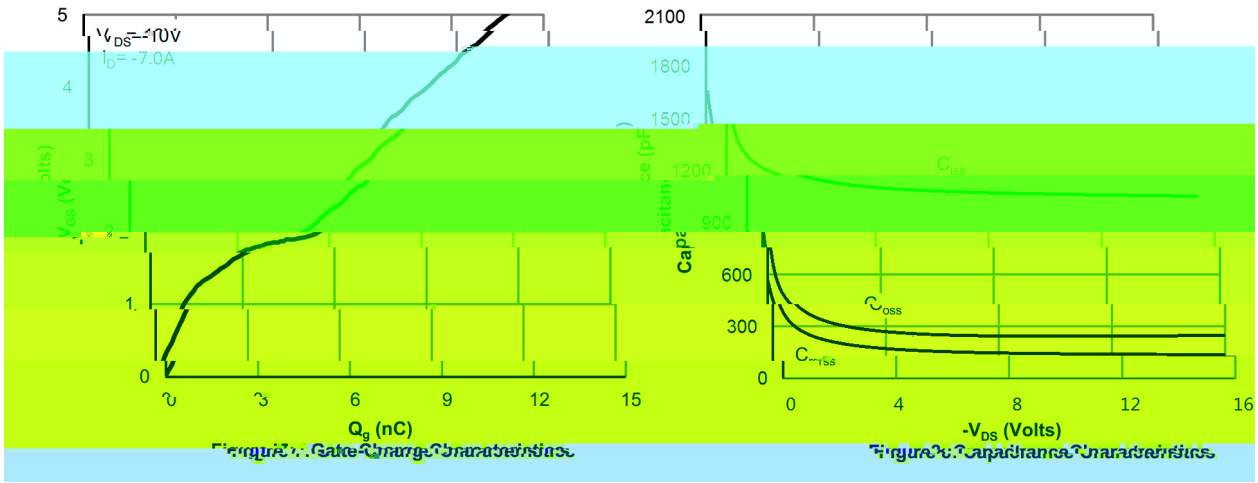
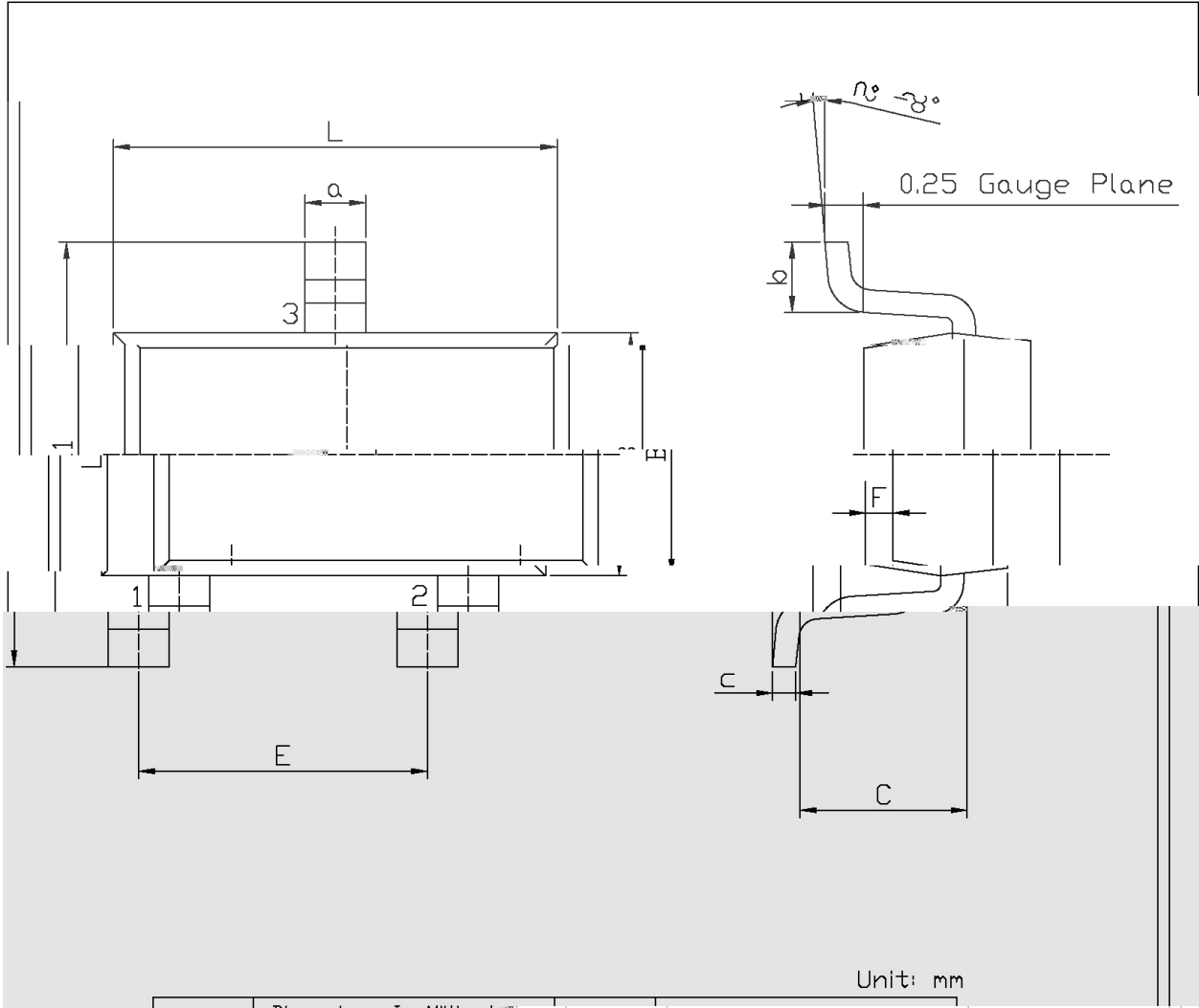

Figure 6: Body-Diode Characteristics





Dimensions in Millimeters

L	2.83	3.02	a	0.35	0.50
B	1.50	1.70	c	0.10	0.20
C	0.90	1.30	b	0.35	0.55
L1	2.60	3.00	F	0	0.15
E	1.80	2.00			

SOT23-3



