

Rev.A Feb.-2025

PDFN5×6A N
Dual N-CHANNEL MOSFET in a PDFN5×6A Plastic Package.

$V_{DS}(V)=30V$ $I_D=41.5A$
 $R_{DS(ON)}@10V<9m$ (Typ. 6.8 m)
 $R_{DS(ON)}@4.5V<15m$ (Typ. 9.8 m)
 HF Product.

PWM LED
 PWM Application, Load Switch, Power Management, Dimming LED.

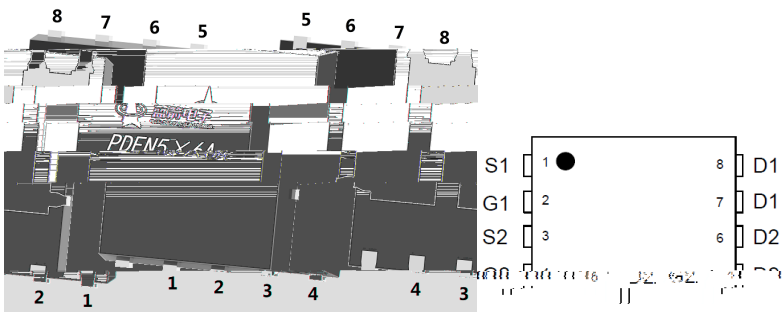
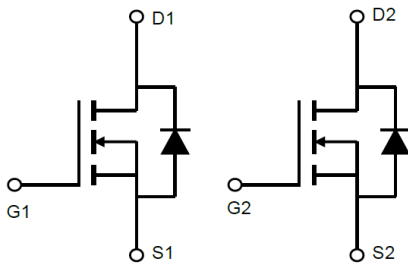

See Marking Instructions.

Parameter	Symbol	Rating	Unit
Drain-Source Voltage	V_{DS}	30	V
Gate-Source Voltage	V_{GS}	± 20	V
Continuous Drain Current	$I_D(T_C=25^\circ\text{C})$	41.5	A
Pulsed Drain Current	I_{DM}	131	A
Power Dissipation	$P_D(T_C=25^\circ\text{C})$	25	W
Junction and Storage Temperature Range	T_J, T_{STG}	-55 to +150	
Maximum Junction-to-Ambient	$R_{JA}(10\text{s})$	45	/W
Maximum Junction-to-Ambient	$R_{JA}(\text{Steady-State})$	65	/W
Maximum Junction-to-Case	$R_{JC}(\text{Steady-State})$	5.0	/W

Parameter	Symbol	Test Conditions	Min	Typ	Max	Unit
Drain-Source Breakdown Voltage	BV_{DSS}	$V_{GS}=0V$ $I_D=250\mu A$	30	36		V
Zero Gate Voltage Drain Current	I_{DSS}	$V_{DS}=30V$ $V_{GS}=0V$			1	μA
Gate-Body leakage current	I_{GSS}	$V_{GS}=\pm 20V$ $V_{DS}=0V$			100	nA
Gate Threshold Voltage	$V_{GS(th)}$	$V_{DS}=V_{GS}$ $I_D=250\mu A$	1.0	1.6	2.5	V
Static Drain-Source On-Resistance	$R_{DS(on)}$	$V_{GS}=10V$ $I_D=10A$		6.8	9	m
		$V_{GS}=4.5V$ $I_D=10A$		9.8	15	m
Diode Forward Voltage	V_{SD}	$V_{GS}=0V$ $I_S=1.0A$			1.2	V
Input Capacitance	C_{iss}	$V_{DS}=25V$ $V_{GS}=0V$ $f=1.0MHz$		1100		pF
Output Capacitance	C_{oss}			125		pF
Reverse Transfer Capacitance	C_{rss}			100		pF
Gate resistance	R_g	$V_{DS}=0V$ $V_{GS}=0V$ $f=1.0MHz$		3		
Total Gate Charge	$Q_{g(10V)}$	$V_{GS}=10V$ $V_{DS}=15V$ $I_D=12A$		14		nC
Total Gate Charge	$Q_{g(4.5V)}$			6.5		nC
Gate-Source Charge	Q_{gs}			2.3		nC
Gate-Drain Charge	Q_{gd}			3		nC

Parameter	Symbol	Test Conditions	Min	Typ	Max	Unit
Turn-On Delay Time	$t_{d(on)}$	$V_{DS}=15\text{ V}$ $V_{GS}=10\text{V}$ $R_L=1.25$ $R_{GEN}=3$		4.5		ns
Turn-On Rise Time	t_r			10		ns
Turn-Off Delay Time	$t_{d(off)}$				15	ns

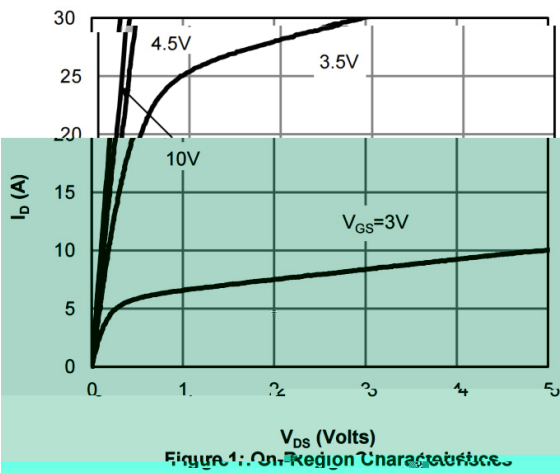
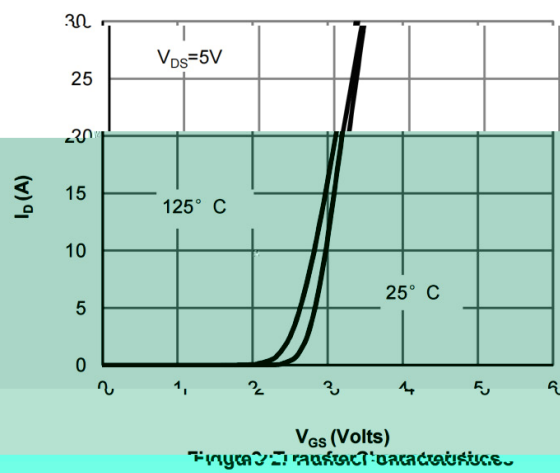
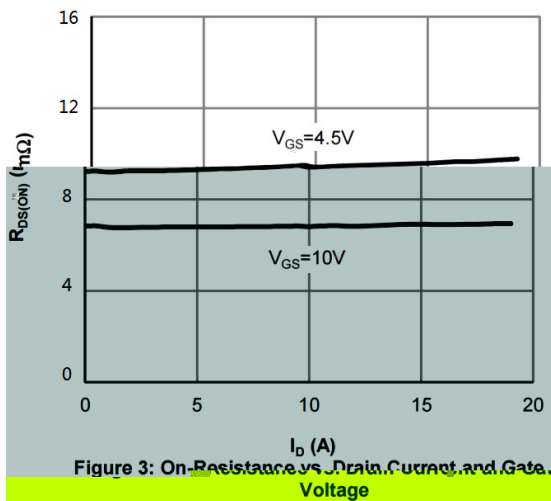
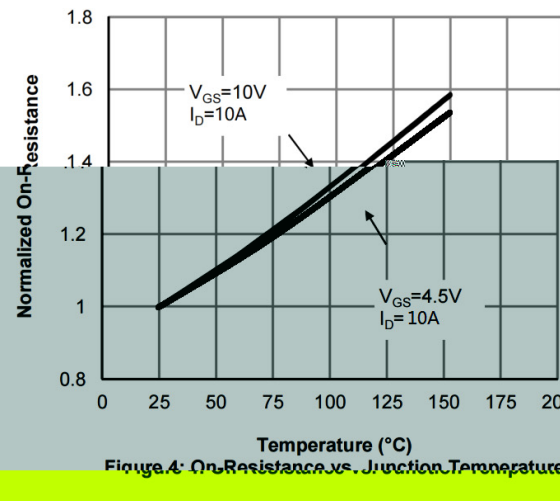
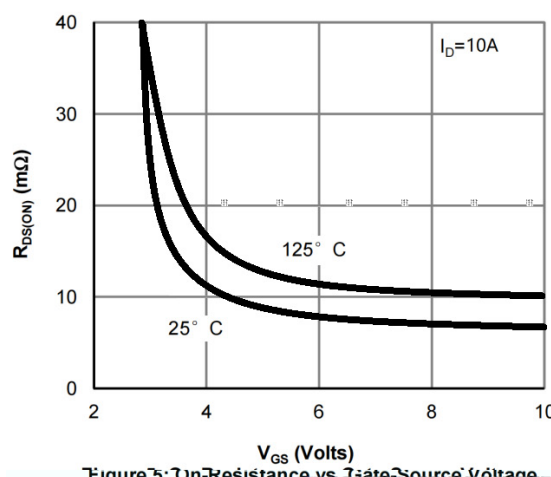
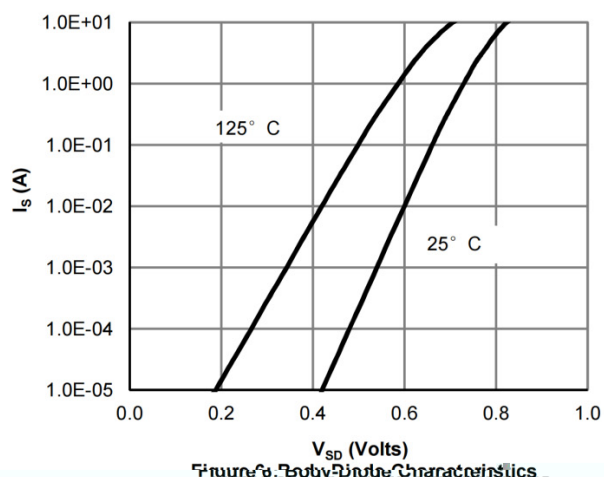
Figure 1: On-Region Characteristics

Figure 2: On-Region Characteristics

Figure 3: On-Resistance vs. Drain Current and Gate Voltage

Figure 4: On-Resistance vs. Junction Temperature

Figure 5: On-Resistance vs. Drain-Source Voltage

Figure 6: Subthreshold Characteristics

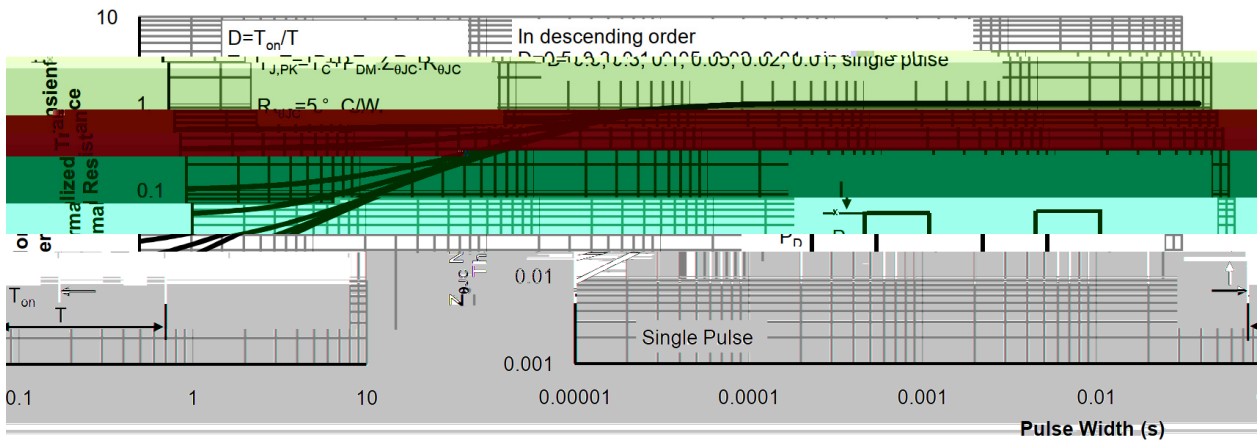
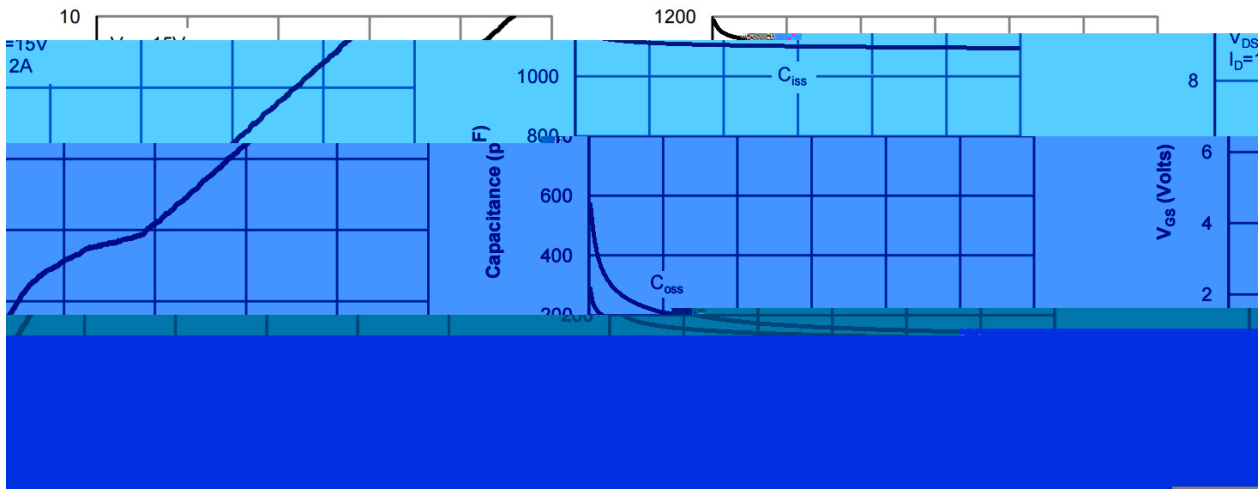
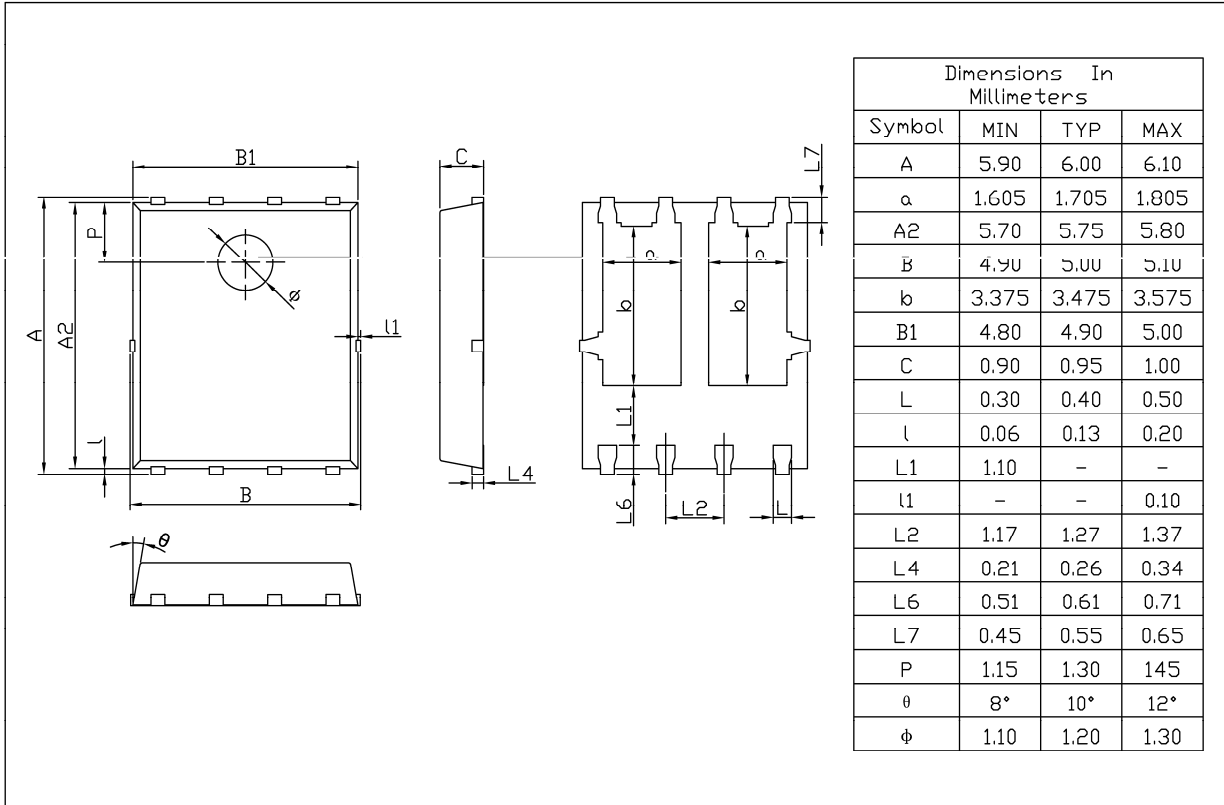

Figure 10: Normalized Maximum Transient Thermal Impedance

PDFN5 X6A

Unit:mm



Rev.01 202209



BR

080N03

Note

BR

Company Code

080N03

Product Type Code

****:

Lot No. Code, code change with Lot No

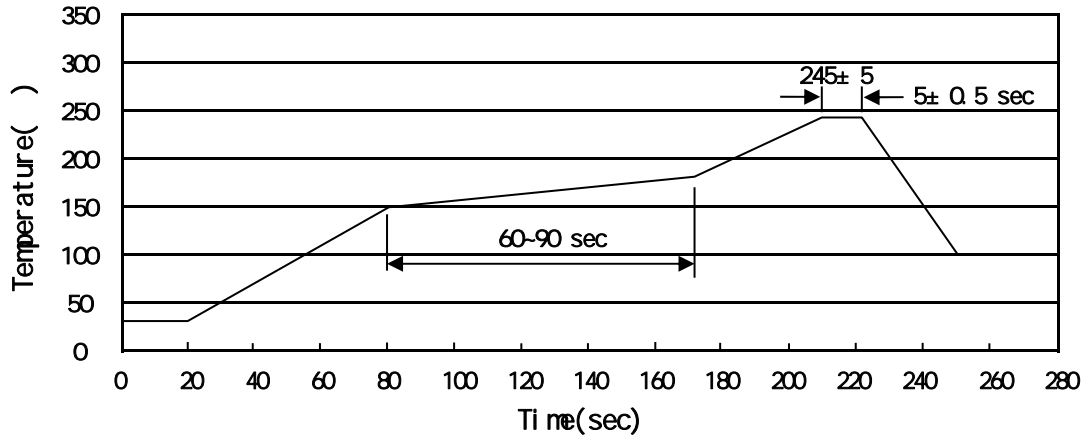

Note:

- | | | | | | |
|---|-------|-----|----|-----------|---|
| 1 | 150 | 180 | 60 | 90sec; | 1.Preheating:150~180 , Time:60~90sec. |
| 2 | 245±5 | | | 5±0.5sec; | 2.Peak Temp.:245±5 , Duration:5±0.5sec. |
| 3 | | | 2 | 10 /sec. | 3. Cooling Speed: 2~10 /sec. |

260±5

10±1 sec.

Temp.:260±5

Time:10±1 sec

/ REEL

Package Type	Units					Dimension (unit mm ³)		
	/	/	/	/	/			
PDFN5x6A	5,000	2	10,000	6	60,000	13"x12	360x360x50	380x335x366