

$\leq \Omega$ Ω
 $\leq \Omega$ Ω

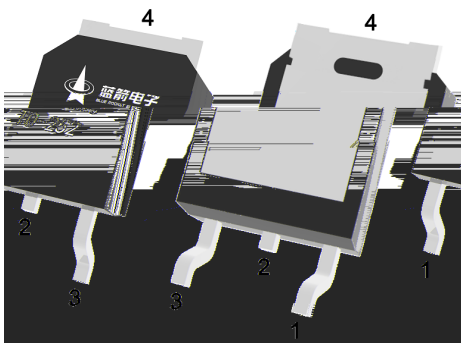

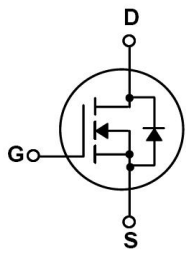

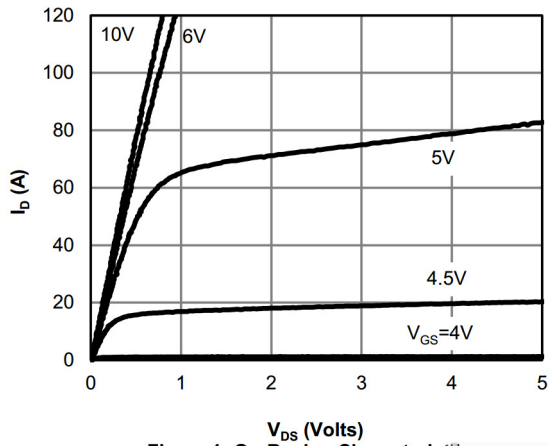

Figure 1: Transfer Characteristics

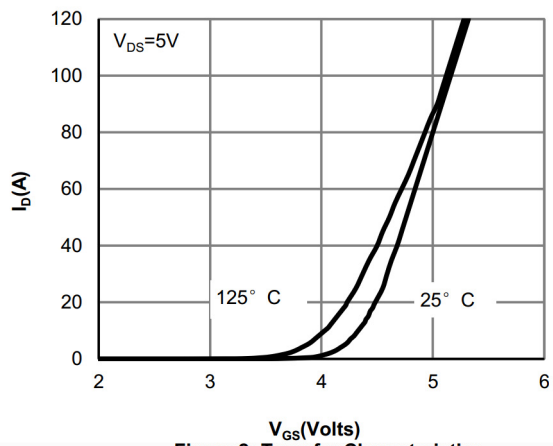
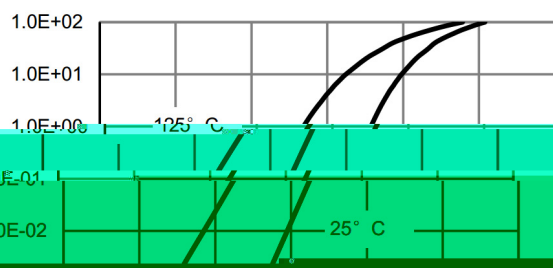
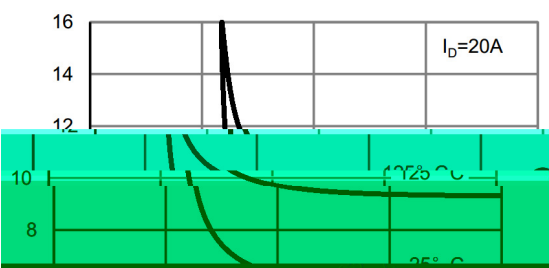
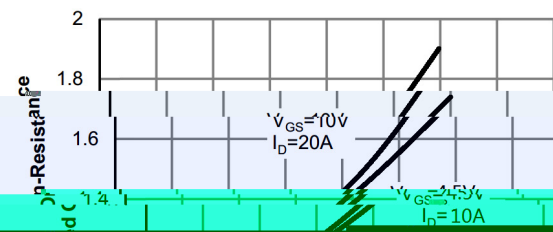
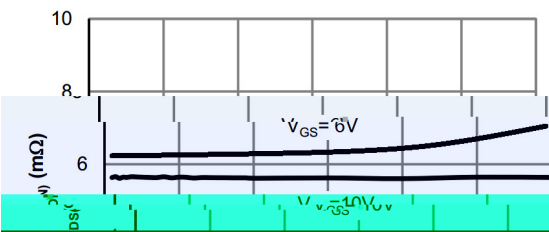

Figure 2: Transfer Characteristics



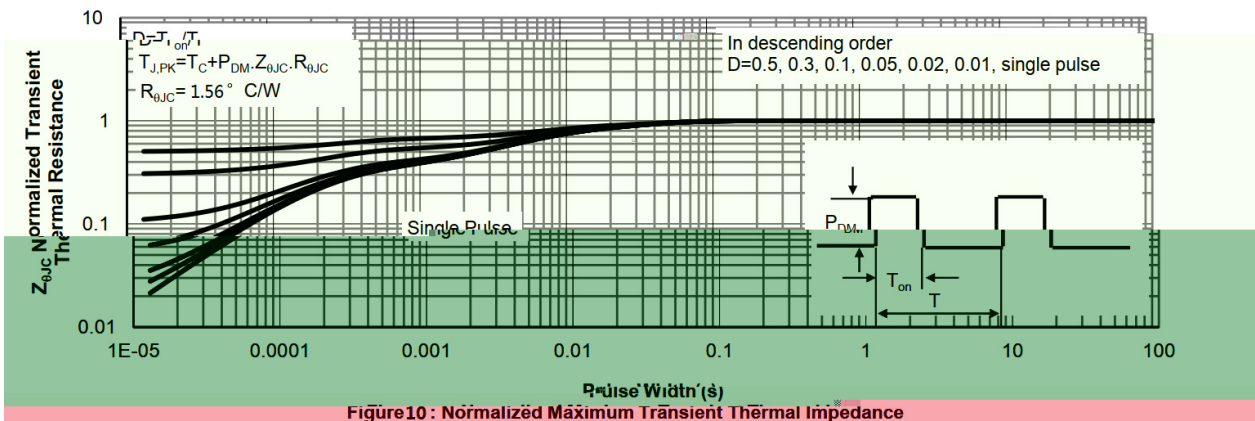
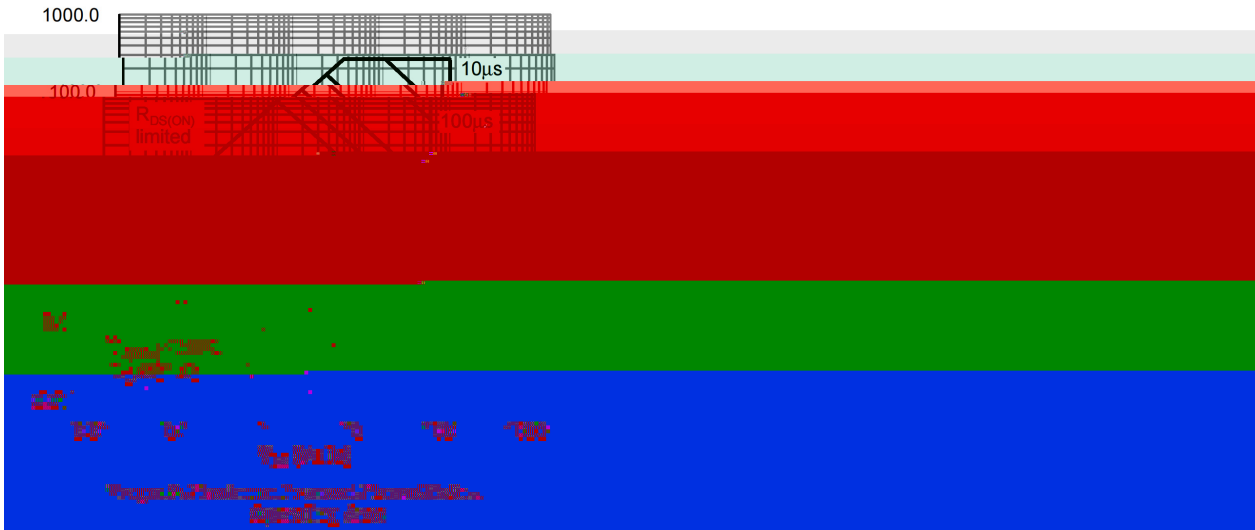
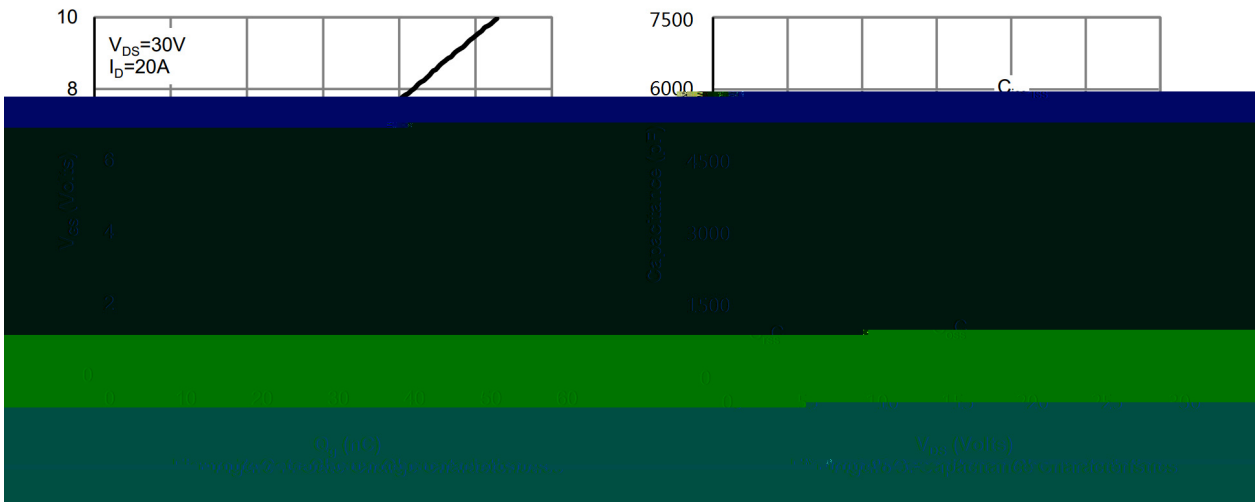

Figure10: Normalized Maximum Transient Thermal Impedance

