

/ Descriptions

/ Features

/ Applications

/ Equivalent Circuit

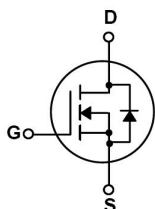

/ Pinning

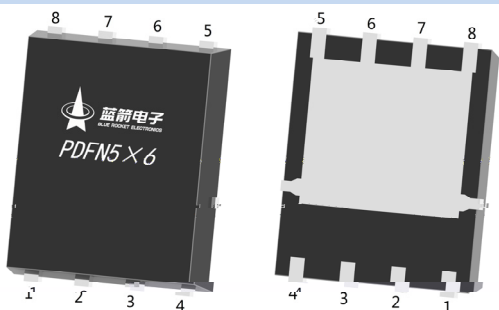

Pin	极性
1	S
2	S
3	S
4	G
5	D
6	D
7	D
8	D

/ Marking

/ Electrical Characteristic Curve

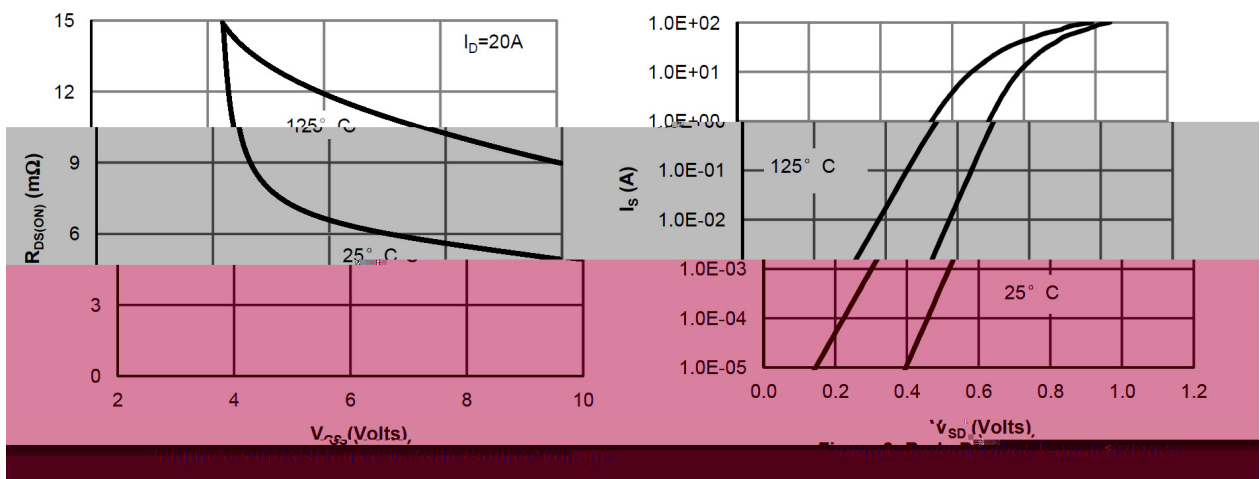
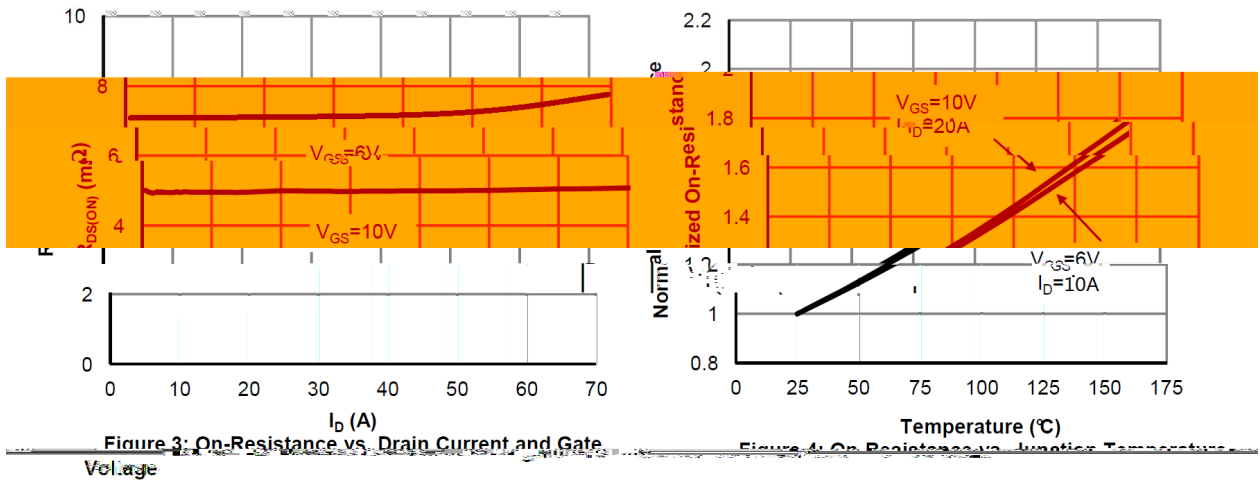
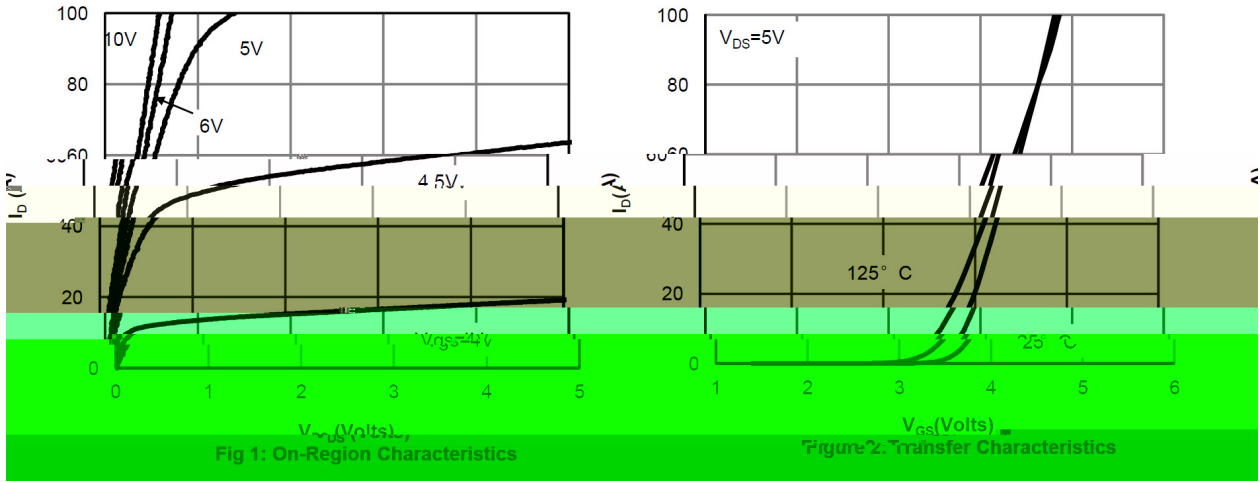

/ Electrical Characteristic Curve

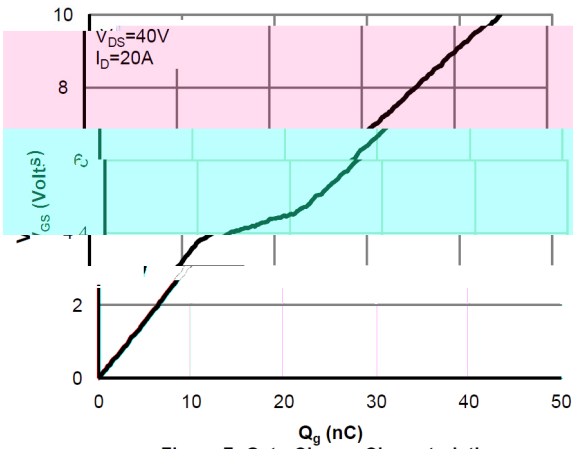

Figure 7: Gate-Charge Characteristics

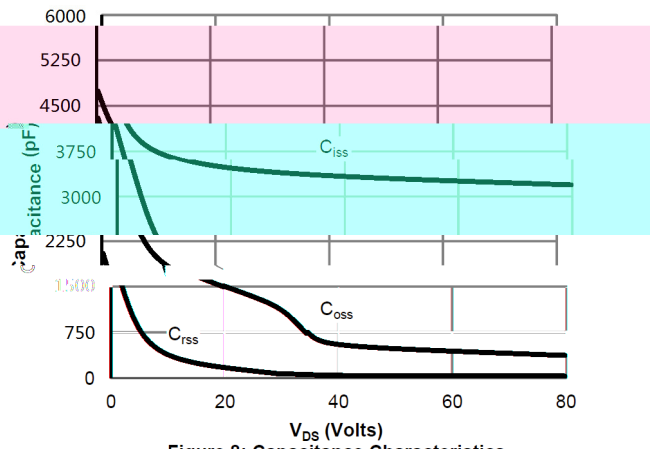

Figure 8: Capacitance Characteristics

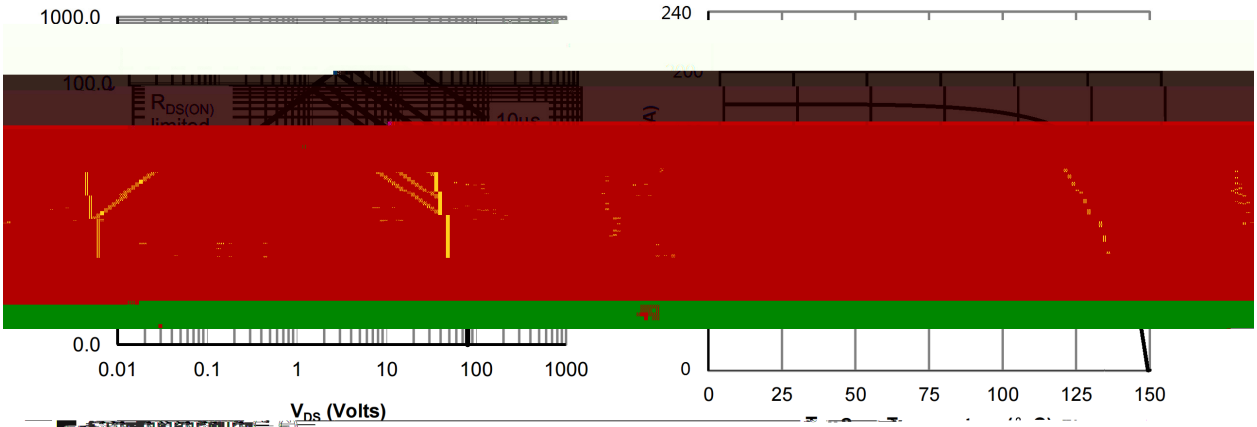

Figure 10: Maximum Continuous Drain Current vs Case Temperature

Figure 9: Maximum Forward Biased Safe Operating Area

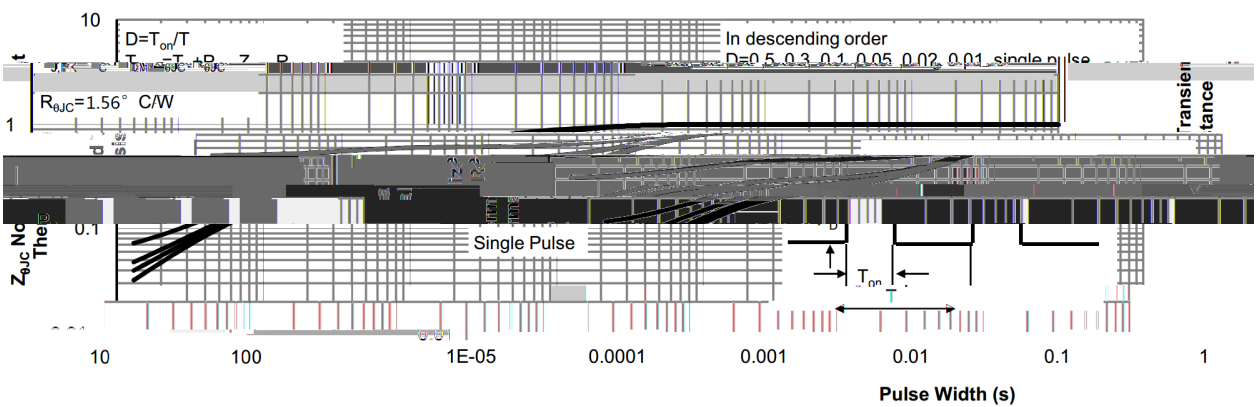
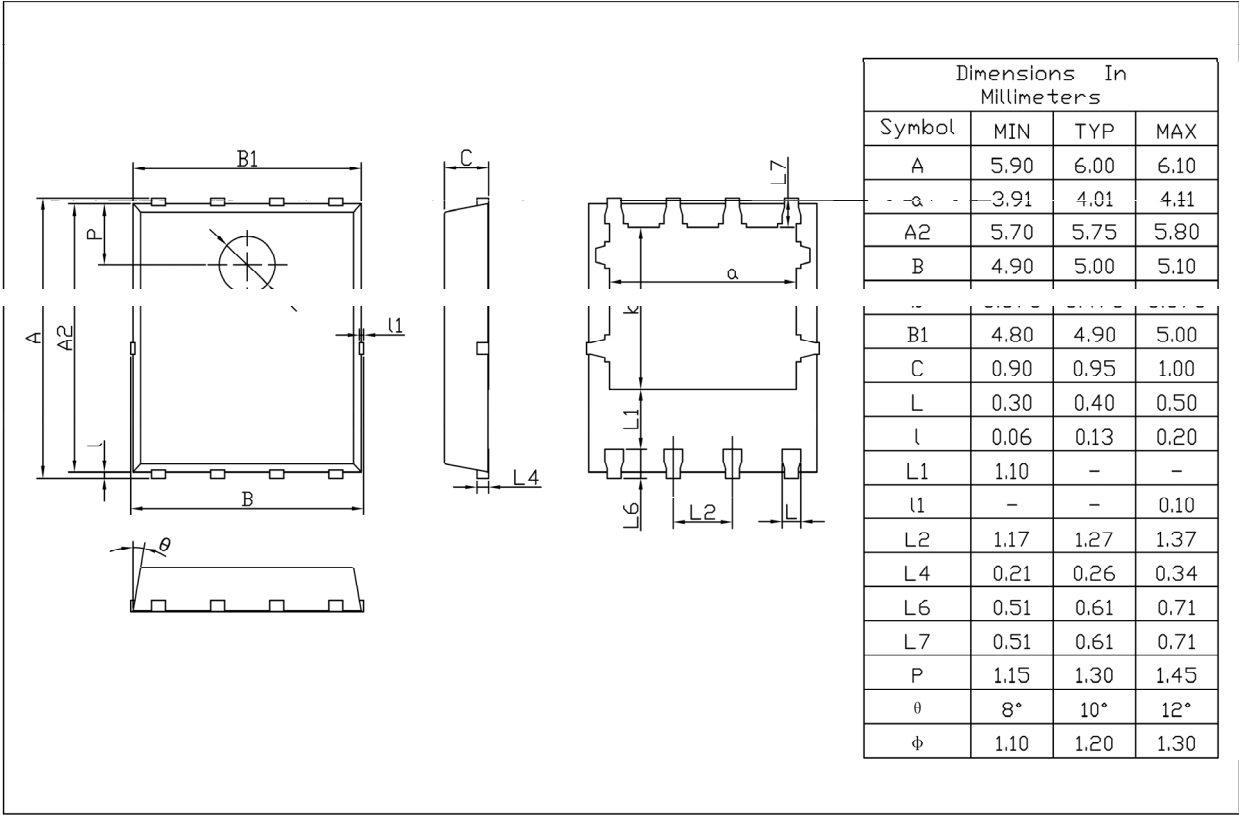

Figure 11: Normalized Maximum Transient Thermal Impedance

/ Package Dimensions

PDFN5 × 6

Unit:mm



Rev.01 202209

/ Marking Instructions

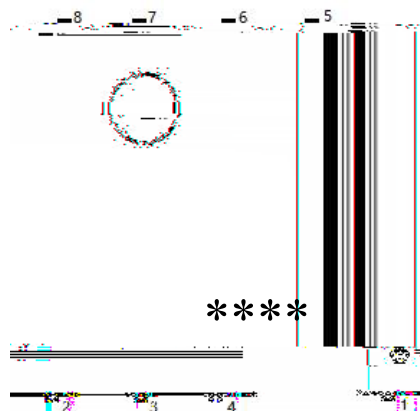

() /

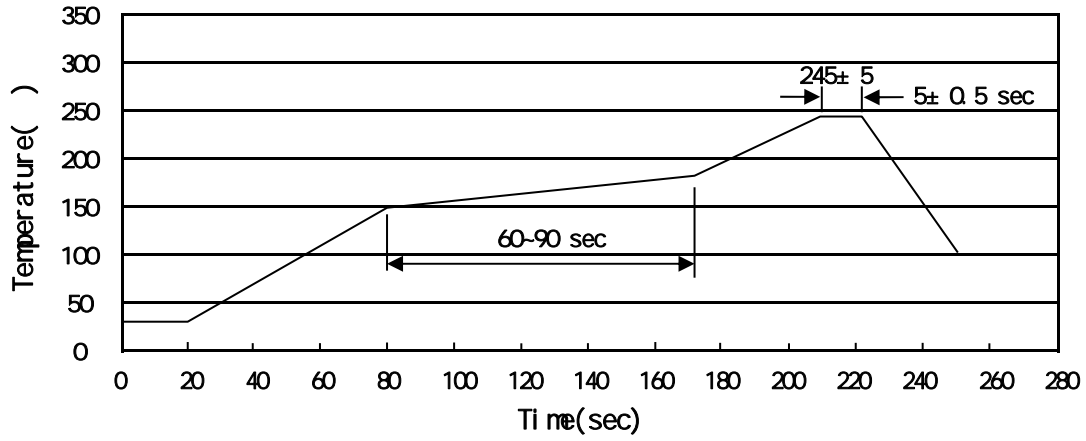

/ Resistance to Soldering Heat Test Conditions

/ Packaging SPEC.

	Units/Reel	Reels/Inner Box	Units/Inner Box	Inner Boxes/Outer Box	Units/Outer Box	Reel	Inner Box	Outer Box
×						×	×	×

/ Notices