

/ Descriptions

/ Features

$\leq \Omega$ Ω
 $\leq \Omega$ Ω

/ Applications

LED

/ Equivalent Circuit

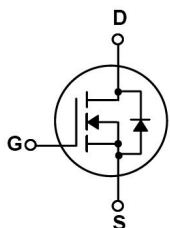

/ Pinning

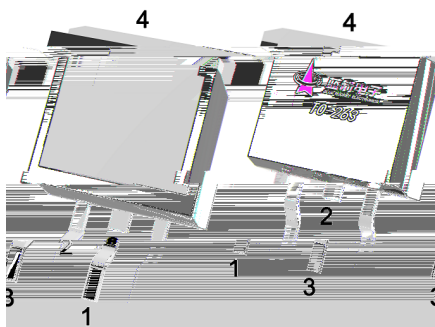

/ Marking

/ Electrical Characteristics(Ta=25)

		Ω	Ω			

/ Electrical Characteristic Curve

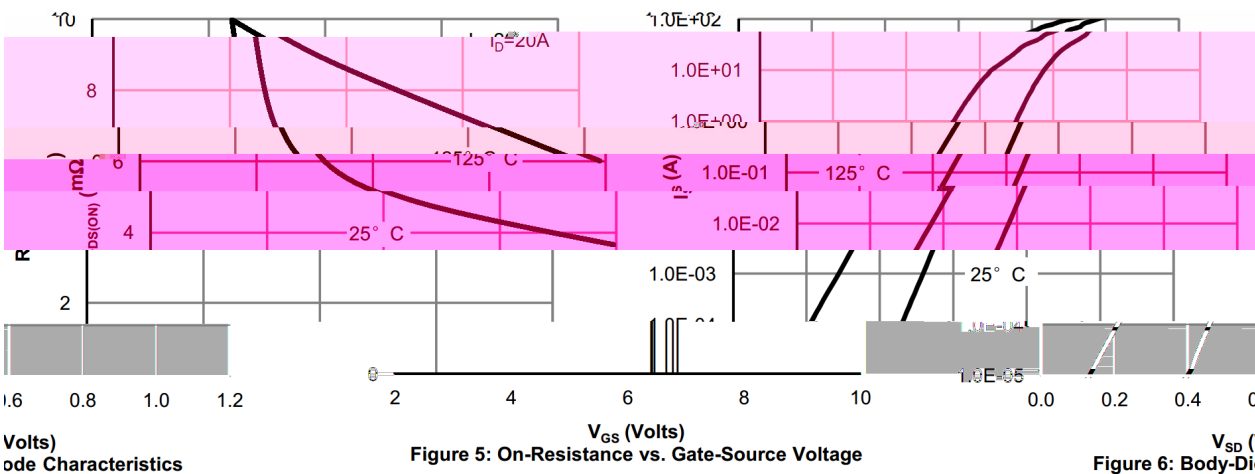
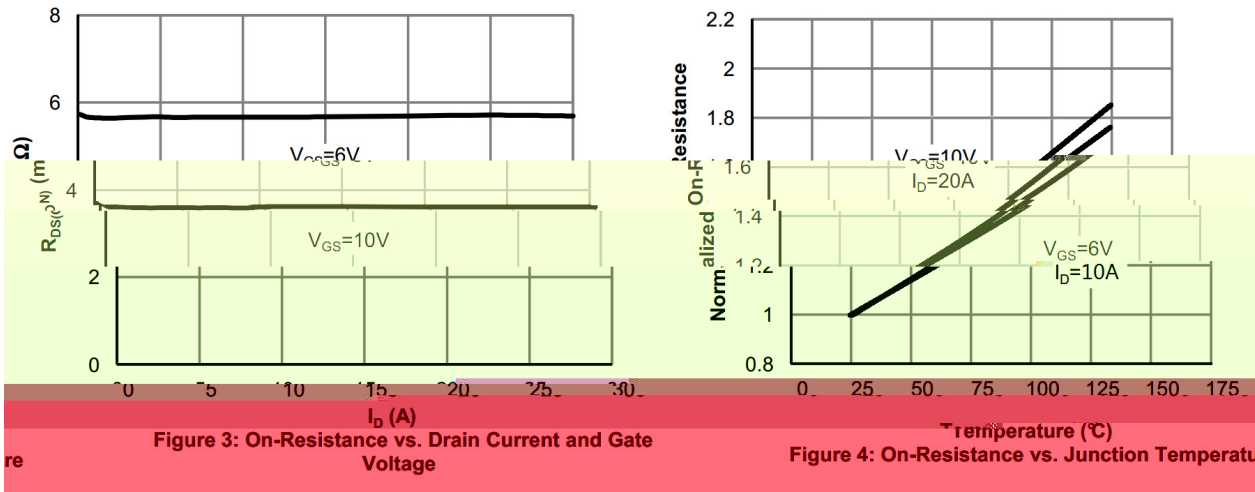
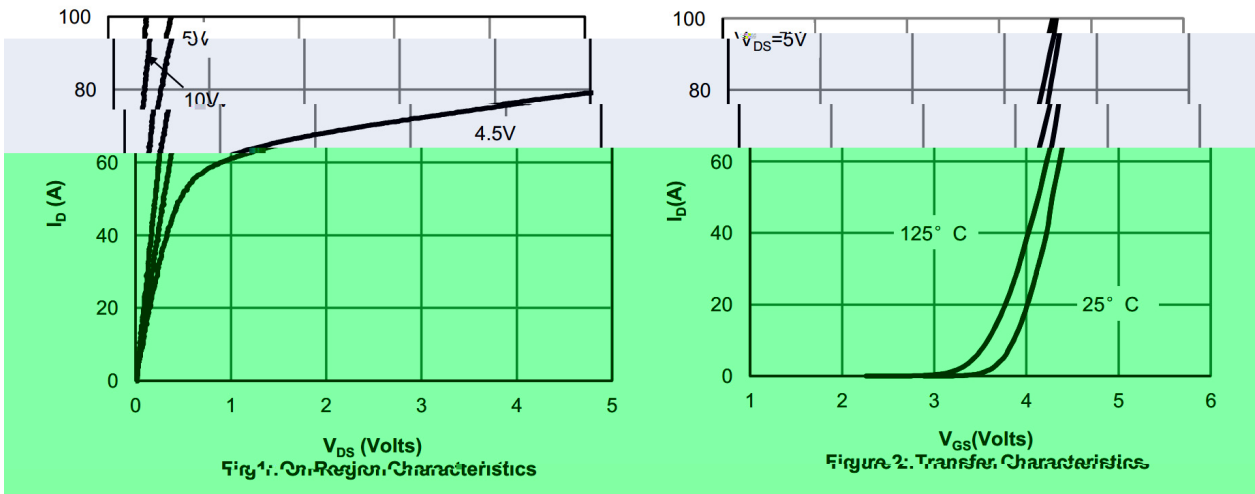

/ Electrical Characteristic Curve

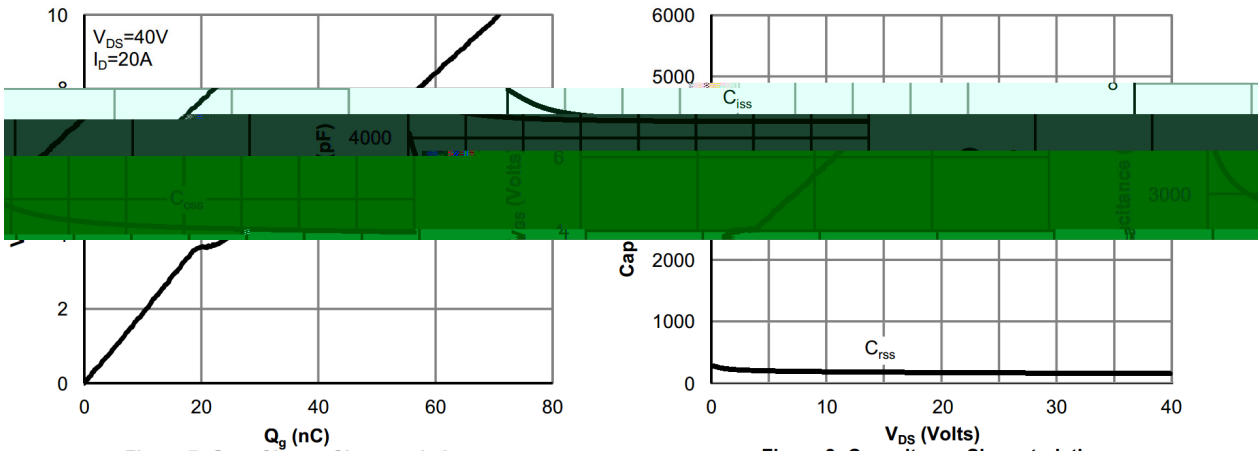

Figure 7: Gate Charge Characteristics Figure 8: Capacitance Characteristics

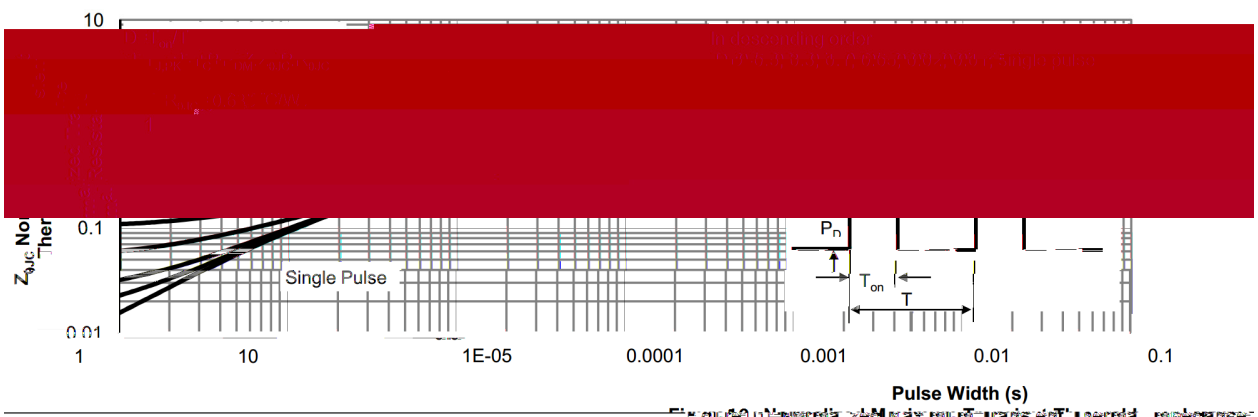
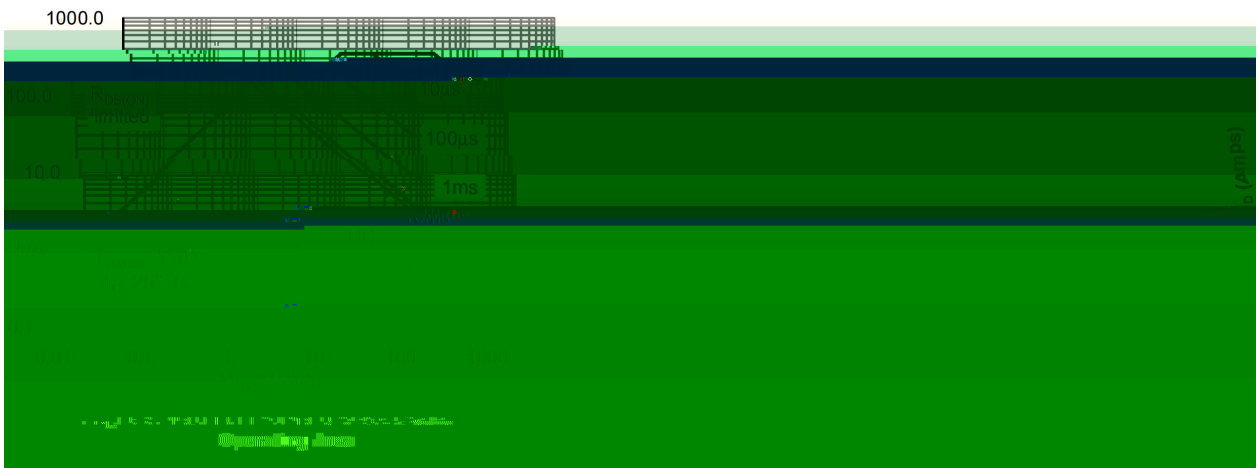

Figure 9: Thermal Impedance Characteristics

BRCS045N08SHBD



DATA SHEET

/ Marking Instructions

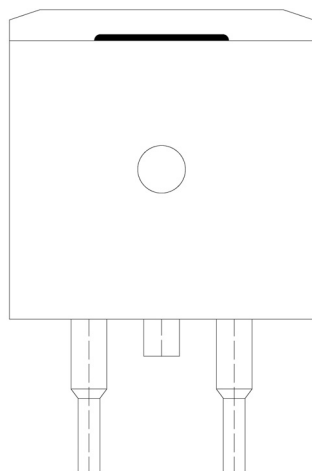

BR

045N08SH

() / R n d d P P d e

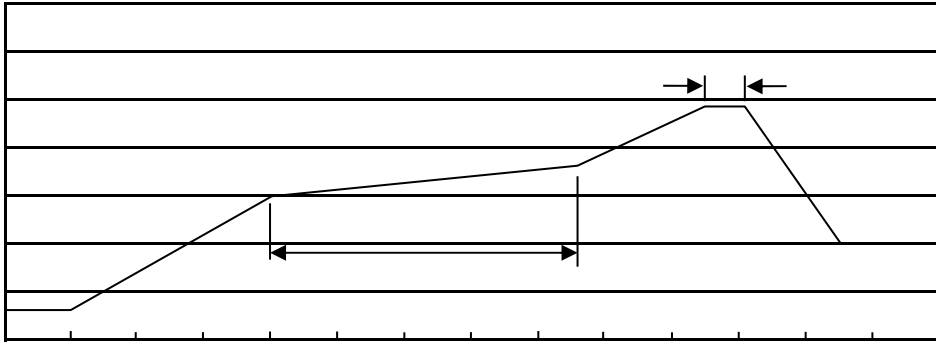

± ± ± ±

/ Resistance to Soldering Heat Test Conditions

± ±

/ Packaging SPEC.

/ Notices