



/ Descriptions

BRCL3230SE / BRCL3230SE
 MOSFET
 BRCL3230SE ESOP-8
 BRCL3230SE

/ Features

- ◆ 23m MOSFET
- ◆ ESOP-8
- ◆
- ◆
- ◆
- ◆ 2 1 2
- ◆ OV
- ◆ 6uA , 3uA ;
- ◆
- ◆
- ◆
- ◆
- ◆
- ◆ ;
- ◆
- ◆
- ◆
- ◆

/ Applications

/ Typical Application

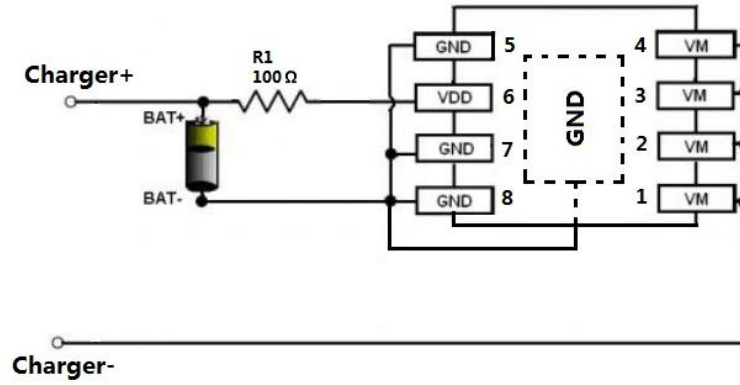

(1)

(2)

:

/ Pinning

1	2	3	4	GND
5	7	8		
6				
9				

/ Marking



Power Dissipation			
			°C

--	--	--	--	--	--	--	--



Equivalent FET on Resistance						
Over temperature protection						



Functional Description

BRCL3230SE

MOSFET

23mΩ



Overcharge Condition

Overdischarge Condition

TDL BRCL3230SE VDL ,
FET VM VM VDD RVMD
IPDN VM VDD RVMD
VM VCHA ,
(VDL) BRCL3230SE FET
VM VCHA ,
VDR



Overcurrent Condition

VM
,BRCL3230SE FET
1 2 ,VM GND RVMS
VM VDD
VM GND RVMS VM VM
1

0V Battery Charging Function

			0V		VDL		IC			
(1)										
(2)	"	0V	"	0V	"	"	0V	"	0V	"
	IC		"	"	"	"	,	"	VDL	"
(3)										
	VM		GND		VM		GND			

Timing Chart

Overcharge And Overdischarge Detection

Timing Chart

Charger Detection

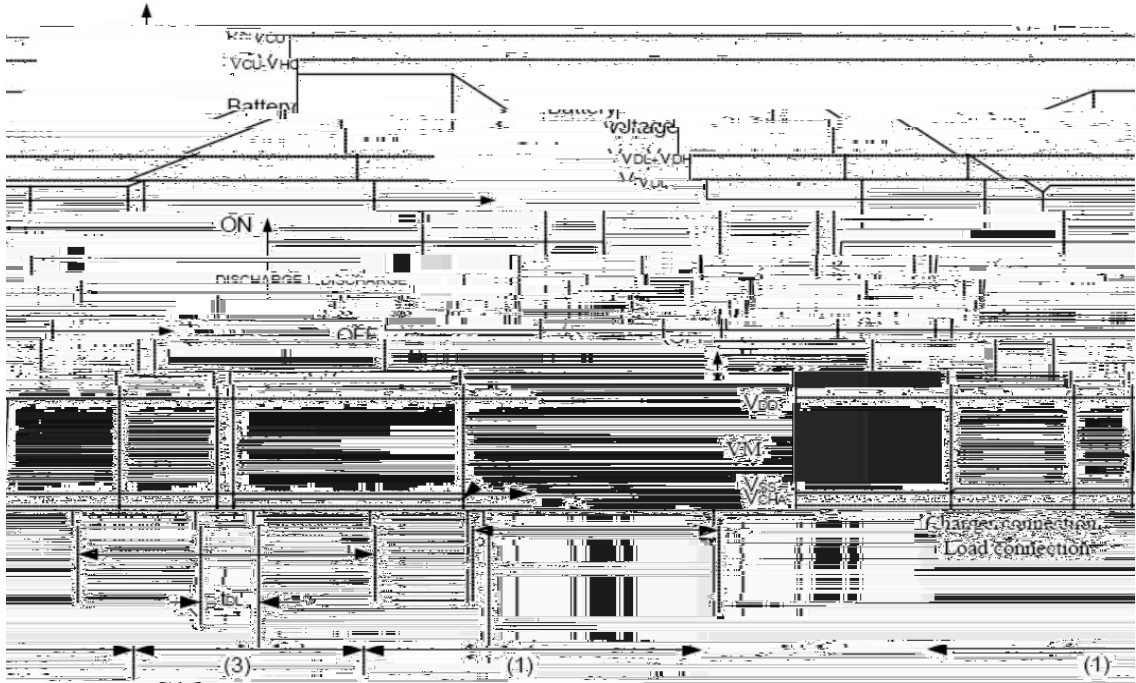

/ Package Dimensions

ESOP-8

Unit:mm

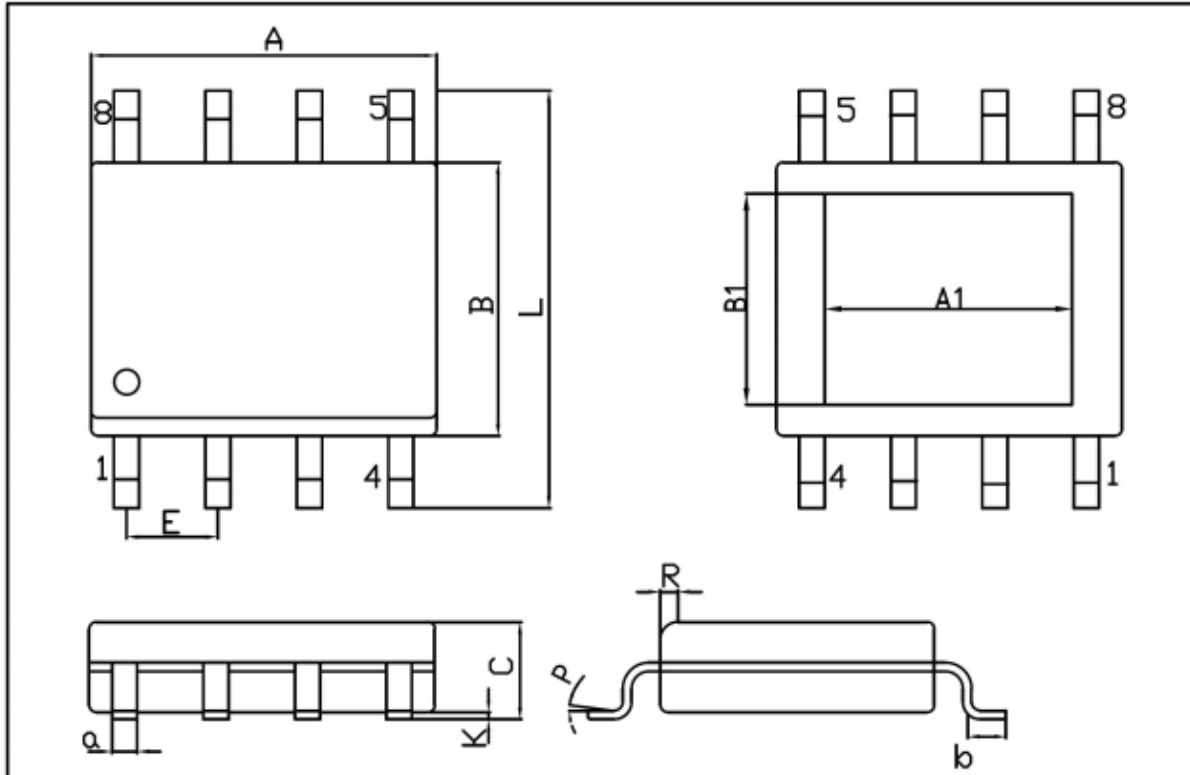

Symbol	Dimensions	Min	Max
C		1.35	1.75
a		0.35	0.49
R		0.30	0.60
P		0°	7°
b		0.40	1.25
B1		2.2	2.6

Symbol	Dimensions	Min	Max
A		4.70	5.10
B		3.70	4.10
L		6.00	6.40
E		1.27BSC	
K		0.02	0.10
A1		3.1	3.5

/ Marking Instructions

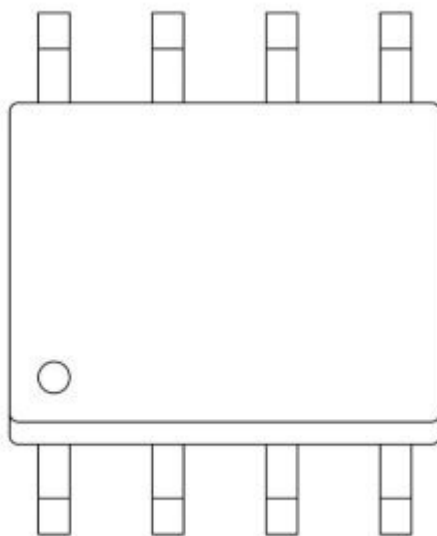

说明：

BR: 为公司代码

3230： 为产品型号

****： 为生产批号代码，随生产批号变化。

