

TO\$))'

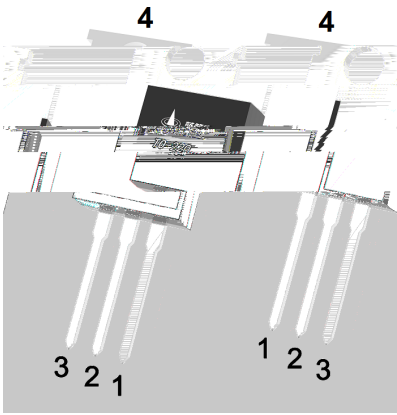

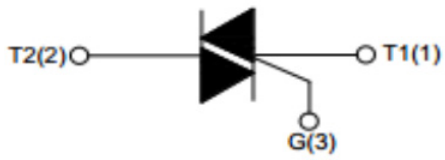
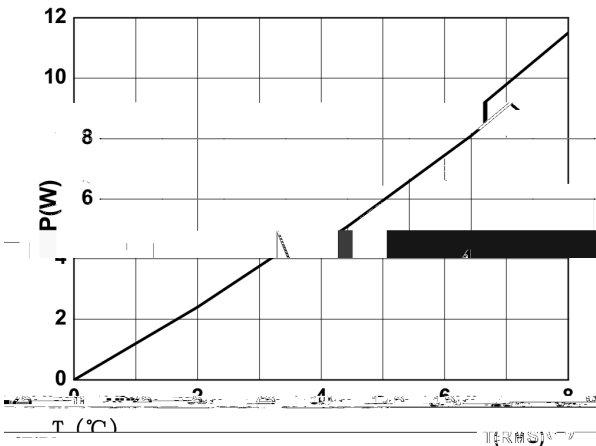

FIG.1 Maximum power dissipation versus RMS on-state current

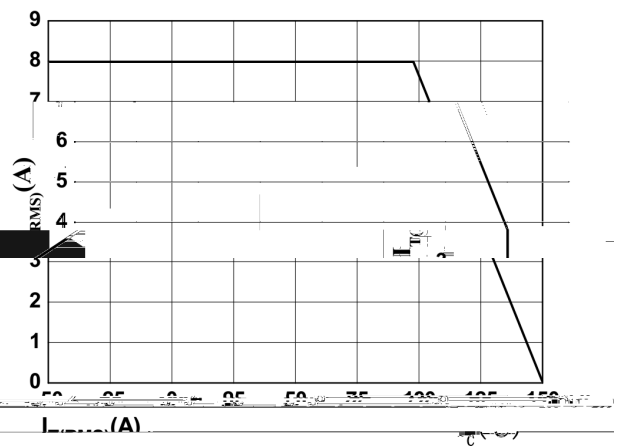

FIG.2: RMS on-state current versus temperature

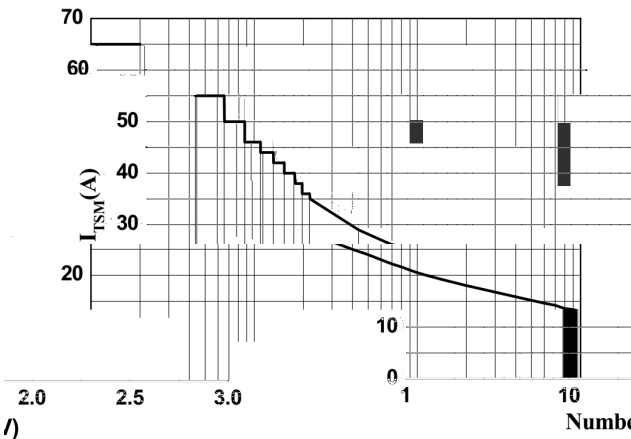

FIG.3: Surge peak on-state current versus number of cycles

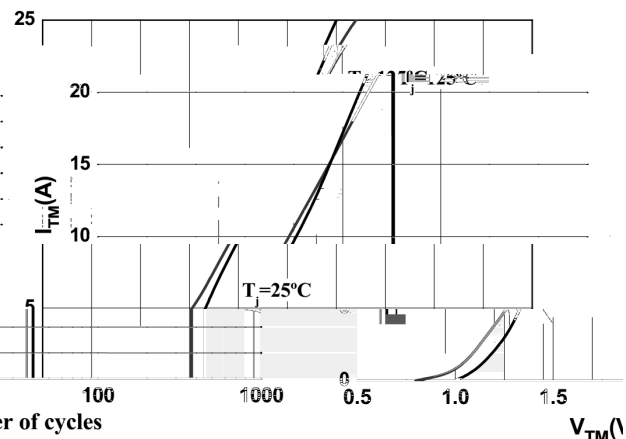

FIG.4: On-state current

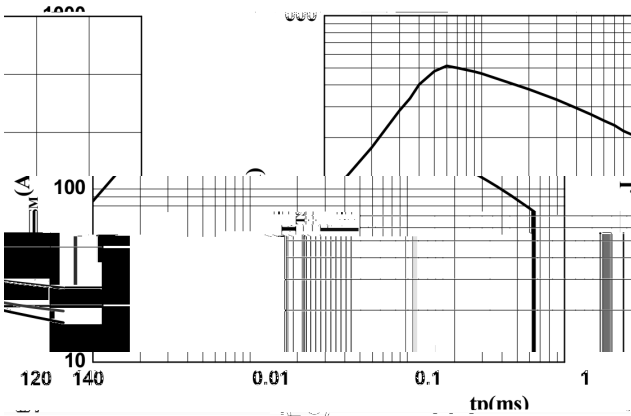

FIG.6: Relative variations of gate trigger

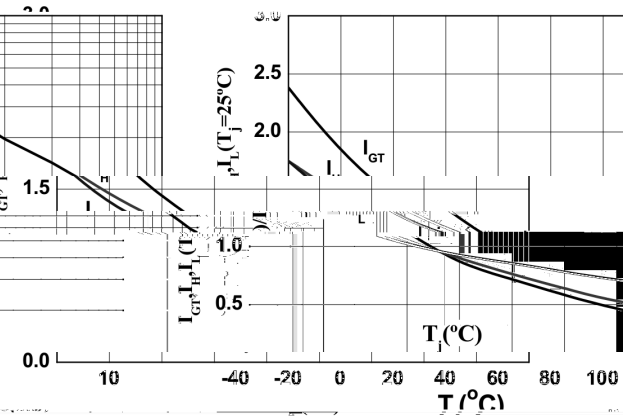
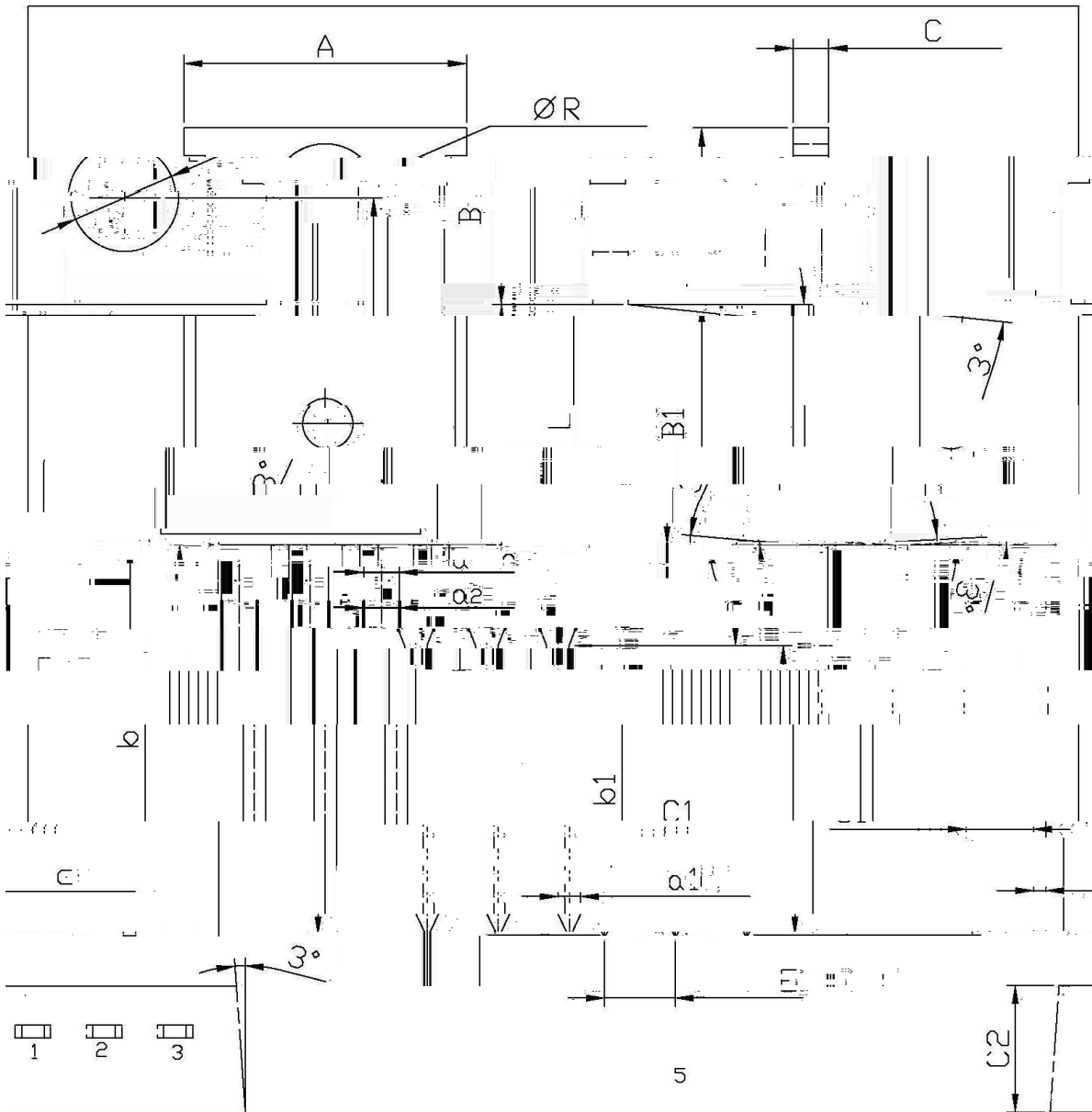

FIG.5: Non-repetitive surge peak on-state current

T0-220

单位: mm



Symbol	Dimensions In Millimeters		Symbol	Dimensions In Millimeters	
	Min	Max		Min	Max
A	9.8	10.2	C	12	14
R	3.56	3.64	B	6.3	6.7
B	15.7	16.1	B1	9.0	9.4
b	12.6	13.6	C1	2.2	2.6

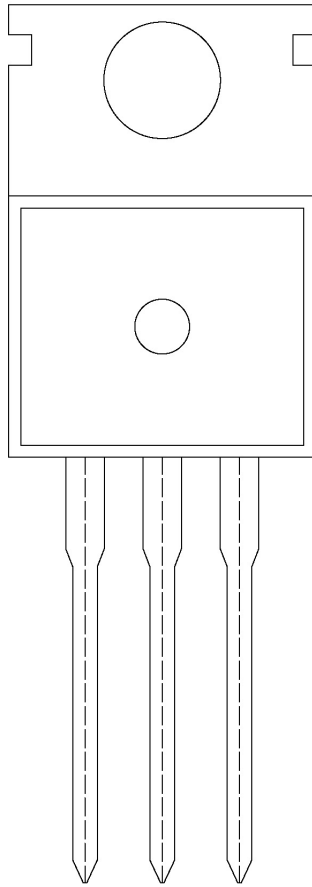

9R

E

I_{GT}

9T' 8' 8

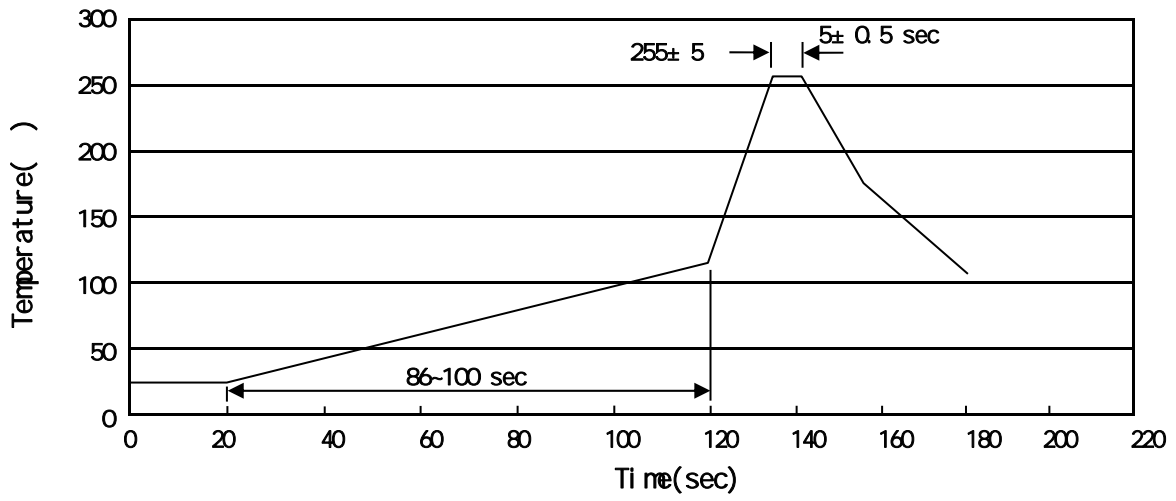

±

±

±

±

±

±

	Units/Bag	Bags/Inner Box	Units/Inner Box	Inner Boxes/Outer Box	Units/Outer Box	Bag	Inner Box	Outer Box
	/	/	/	/	/			

	Units/Tube	Tubes/Inner Box	Units/Inner Box	Inner Boxes/Outer Box	Units/Outer Box	Tube	Inner Box	Outer Box
	/	/	/	/	/			