

		~	
		~	
		~	°C
			°C
		~	°C

	△		~ °C			
	△ △	△				
		△				
			Ω			μ
	△		Ω			μ
			~ °C			

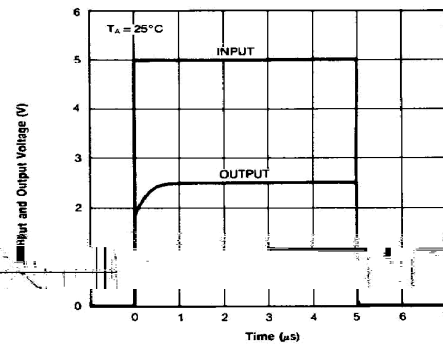

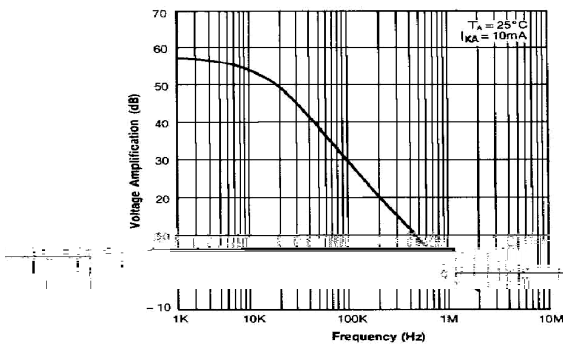
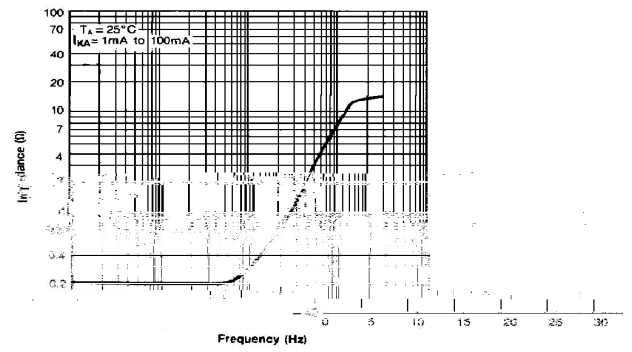
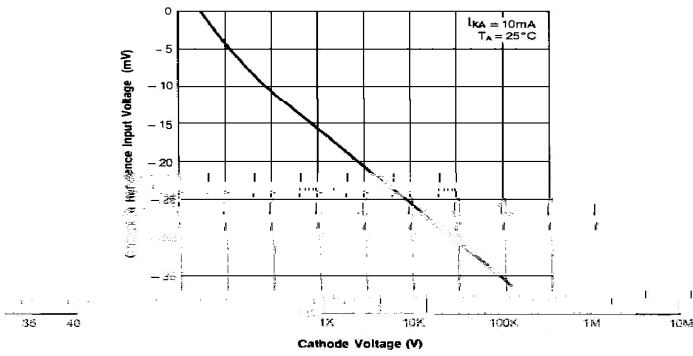
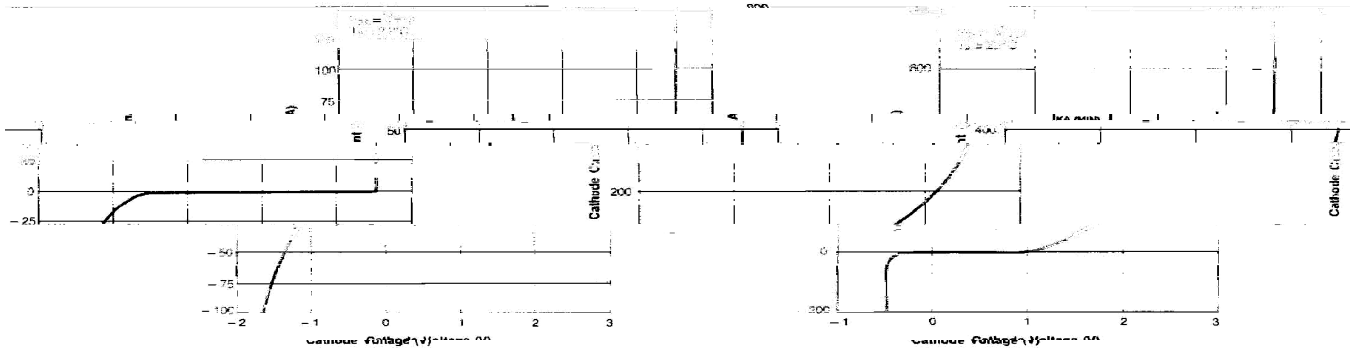
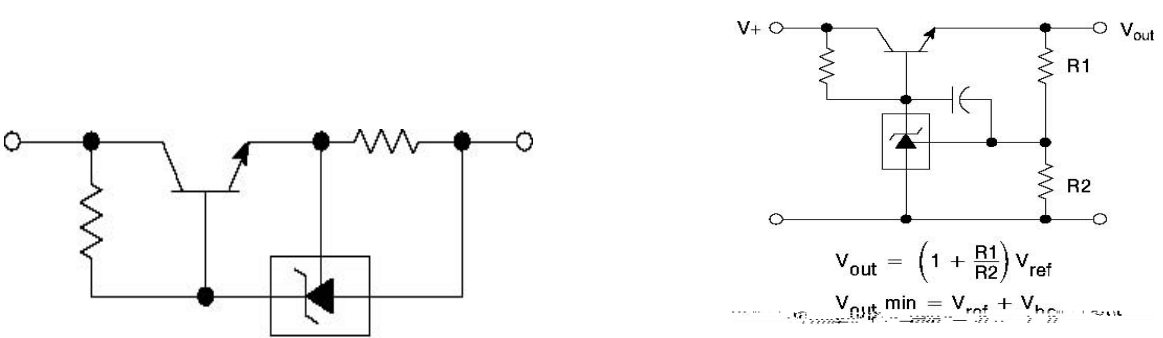
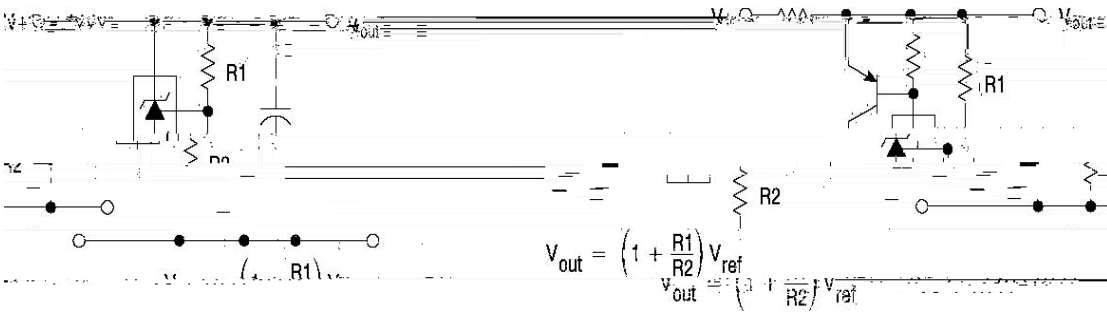
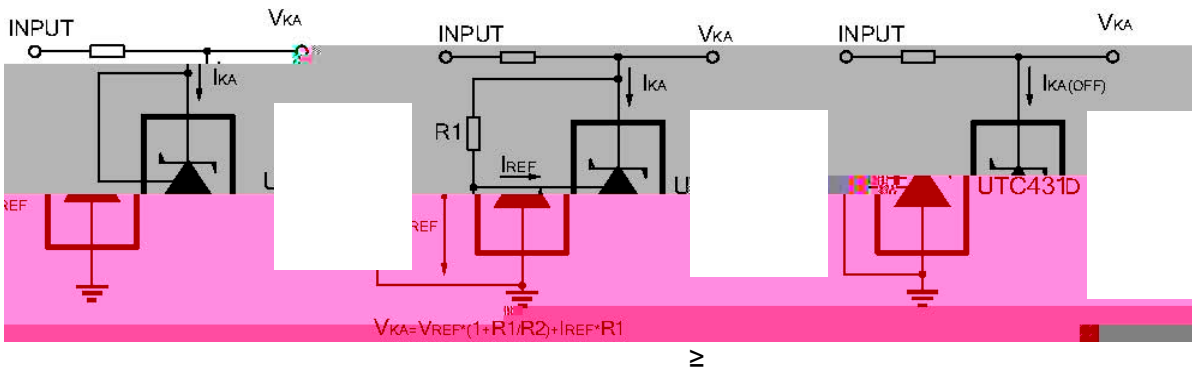
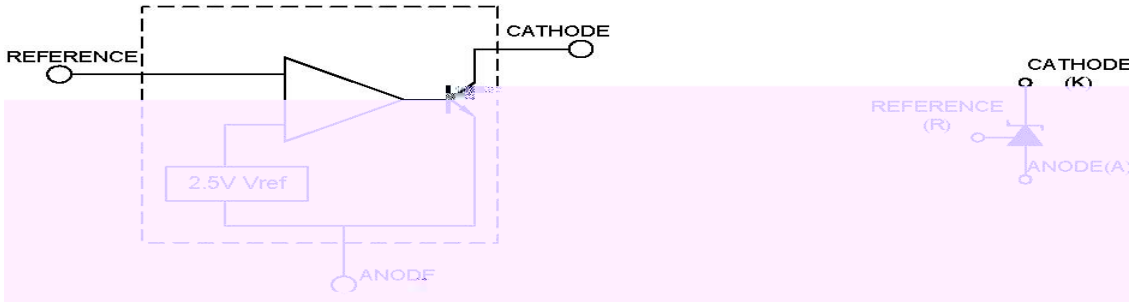

SOT-23

单位: mm

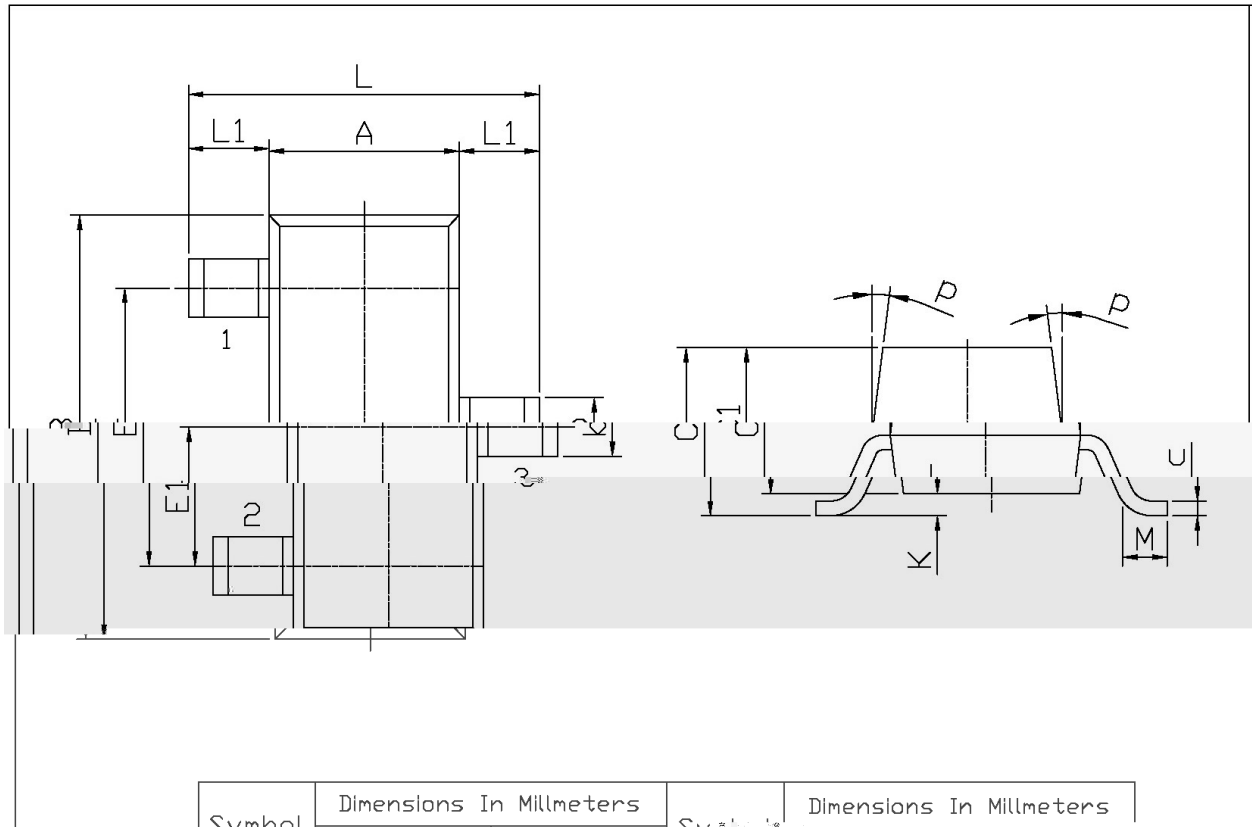

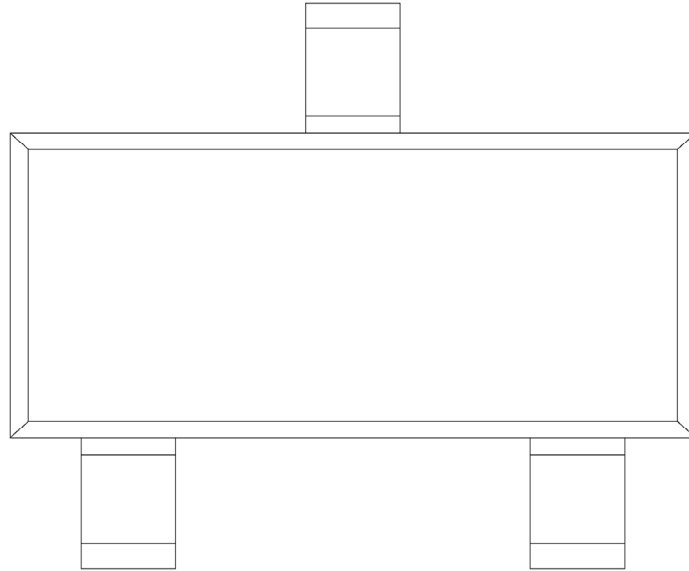

BR
431

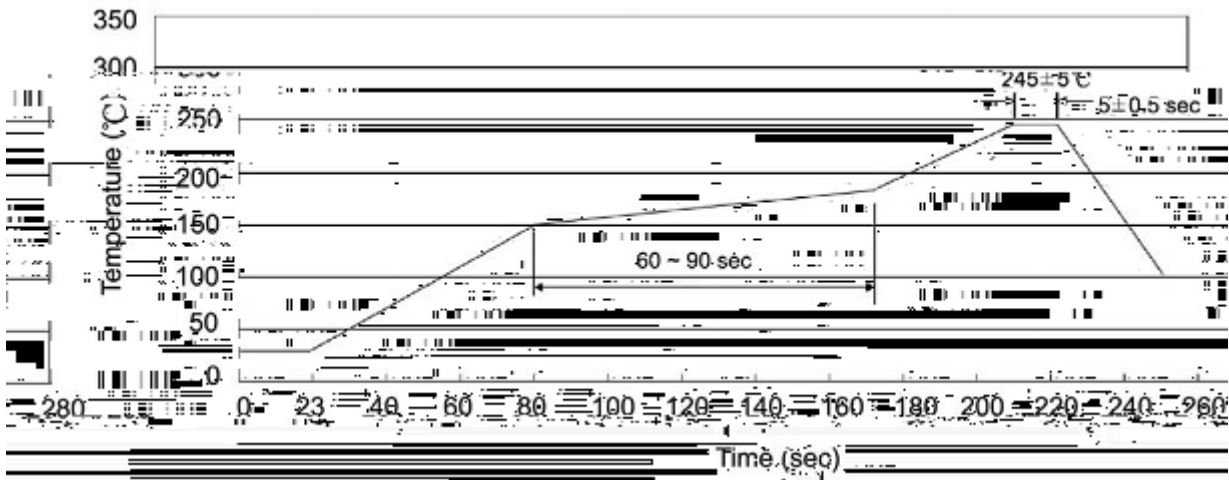

±

±

±

±

±

±

°C

封装形式	包装数量					包装尺寸		
	Units/Reel 只/卷盘	Reels/Inner Box 卷盘/盒	Units/Inner Box 只/盒	Inner Boxes/Outer Box 盒/箱	Units/Outer Box 只/箱	Reel	Inner Box 盒	Outer Box 箱
SOT-23	3,000	10	30,000	6	180,000	7" ×8	180×120×180	390×385×205